

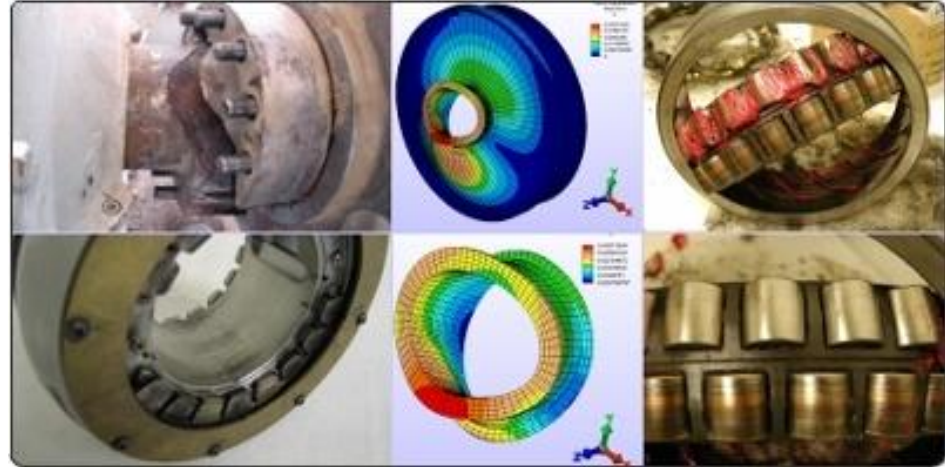

A tradition in excellence dating back to the 1950's, Rotor Bearing Technology & Software (**RBTS**), established in 1986, provides engineering services and software to manufacturers and end users in a diverse range of industries for the analysis of rotating machinery dynamics, bearings, bearing systems, and their structural components. RBTS brings a versatile, yet highly specialized perspective to the solution of commonplace as well as unique engineering problems.

Our software, Advanced Rotating Machinery Dynamics (**ARM D**), is recognized as the worldwide leader for rotating systems and support bearings design, performance evaluation, and troubleshooting.



Services

- Rotor Dynamics
- Torsional Vibration
- Bearings & Bearing Systems
- Field Measurement & Analysis
Vibration, Strain, Modal & Balancing
- Failure Analysis & Corrective Actions
- Feasibility, Retrofit, & Design Audits
- Training & Technology Transfer

Software

- Rotor Dynamics
- Torsional Vibration
- Fluid-Film Bearings
- Rolling-Element Bearings
- Lubricant Analysis
- Customized Software
for Rotating Machinery
Dynamics and Bearings

Sample Industries Served

- Aerospace
- Automotive
- Chemical & Petrochemical
- Machine Tools
- Medical
- Mining & Ore Processing
- Oil & Gas Production & Distribution
- Power (Fossil, Hydro, Nuclear)



Profile **Company Profile & Introduction – A Tradition in Engineering Excellence**

Established in 1986, RBTS offers engineering services in rotating machinery dynamics, bearing systems, and structural engineering. RBTS' principals bring a versatile, yet highly specialized perspective to the solution of commonplace as well as unique engineering problems dating back to the 1950's.

RBTS prides itself on its ability to perform technical analyses of the **highest professional quality**, using **advanced techniques** and equipment, within restricted **time frames**. Offering a variety of services in rotating machinery dynamics, bearings design and analysis, and structural/mechanical engineering.

An international leader in the design and development of software for rotating machinery dynamics, bearings, and seals, RBTS offers expertise in advanced rotor dynamic technologies. Our engineering software, Advanced Rotating Machinery Dynamics (**ARMD**) is currently in use by major corporations worldwide and it is recognized as the worldwide leader for rotating machinery dynamics (lateral and torsional vibration), bearings, and bearing systems.

Through its state-of-the-art software and service programs, RBTS provides computer-assisted technologies to companies to help them "test" the performance of rotating machinery during development and analyze machine failure in operation.

Gearbox Support Frame Dynamic Analysis

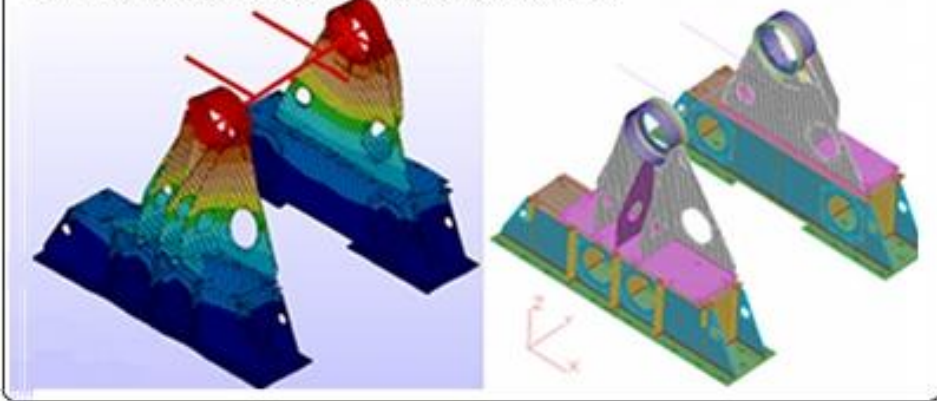

ARMD for Windows 5.8

Advanced Rotating Machinery Dynamics

Dynamic Analysis Rotor Dynamics Torsional Vibration	Fluid Film Bearings Journal Conical Thrust Tilting Pad	Viewer Utilities Text Plots Bearing 3D Shaft
Lubricant Properties Viscosity	Rolling Element Bearings COBRA	Tools Wear-ring AeroCC

Click a button to run a module. Right-click a button for module help. Copyright © 1986, 2013 RBTS Inc.

Sample & select RBTS' accomplishments include:

- Design, development, prototype manufacturing, and testing of advanced technology systems such as implantable human heart assist blood pumps and high-speed dental drills.
- Design audits (rotor dynamics, torsional vibration, bearings, bearing systems, and support structures to assure reliable operation) of rotating systems and their support bearings for a wide spectrum of machinery ranging from fractional horse power to 1100MW, and operating at zero to over 100K rpm.
- Vibration/failure-root-cause analysis and corrective actions of turbomachinery, from a small size turbine (0.10" in diameter and speeds in excess of 250K rpm) to a large size 66,000 HP electric motors and multi-stage compressor drive trains.
- Failure root-cause analysis and development of design modifications to bearings and lubrication systems in large size tumbling mills, coal pulverizers, and crushers. Bearing performance evaluation and design modifications have been developed for small size 16.0" diameter journals utilized in cone crushers to large size 140.0" trunnion diameter for ore processing equipment.
- Structural deformation and its interaction with support bearings in large-size tumbling mills, coal crushers, and antennas. Develop structural modifications to eliminate undesirable behavior.



- Failure analysis and cost/time effective solution of bearings, lubrication systems, and vibrations of steam turbine generator sets utilized in power plants.
- Perform vibration and failure analysis and develop design modifications to rotating assembly, bearings, lubrication systems, and bearing support structure for hydroelectric-turbine-generator units ranging in size from a 20.0" to 160.0" journals with speeds of 75-300 rpm.
- Pulsation and vibration analysis in various piping systems and at various plants, have been conducted with design modifications recommended to reduce and/or eliminate problems. Various equipment have been examined including engine compressor assemblies, gas compressor assemblies, triplex water injection units, and quintuplex pumps.
- Hundreds of torsional qualification analyses, design modifications, and testing of mechanical drive trains. Driven equipment included reciprocating, screw, and centrifugal compressors/pumps, driven by electric motors, steam/gas turbines, diesel/gas engines, or a combination driver. Equipment range in power from 50 hp to over 100K hp.

**400MW Steam
Turbine-Generator Set****6 Megawatt Generator with Cooper
Bessemer LSV16 – SG Engine Drive**

RBTS takes an integrated approach to problem solving, analyzing the entire project to determine the impact of each component. The collective expertise of RBTS' professionals means that our clients receive both generalized as well as specialized consultation.

Through its principals, RBTS offers more than 60 years of combined experience. Senior consultants from these and other engineering fields also work with us. Together, the RBTS network provides the most comprehensive engineering expertise available.



Comprehensive technical services - mechanical/structural analysis, design and development, and failure and safety studies - are available through RBTS. The firm's professionals also serve as troubleshooters and expert witnesses on a broad range of engineering-related issues.

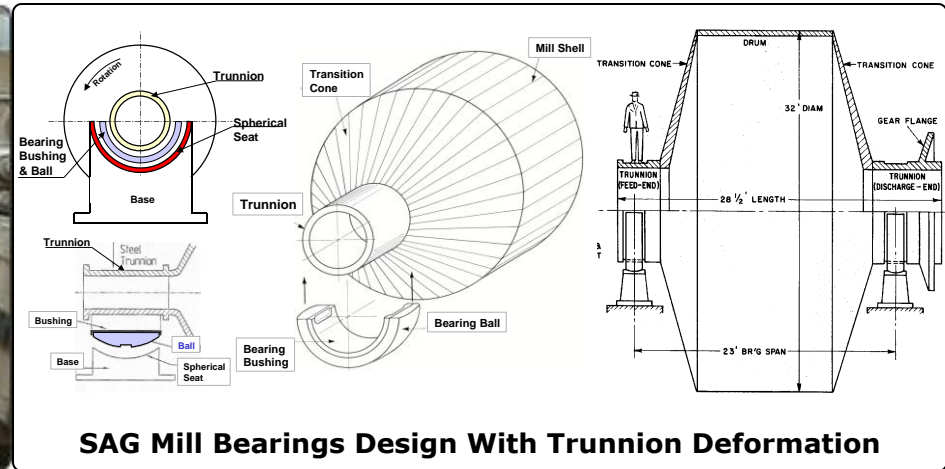

Tailored Consulting Arrangements

RBTS engineers are available for both short and long term consulting assignments. Arrangements are flexible and fees (rates) are competitive. Prior to beginning work, RBTS provides each of its clients with a detailed project schedule and estimate of costs.

From comprehensive project management to specific problem solving to software packages, RBTS technical experts stand ready to work with you to develop an individually tailored, cost-effective plan to meet your specific problems. **Contact RBTS to learn how they can help with your engineering needs.**

Immediate Response to Customer Needs

RBTS prides itself on its expeditious response to customer needs for emergency engineering services. RBTS' team of experts will work closely with its customers and can be readily available at the job site when and as needed.

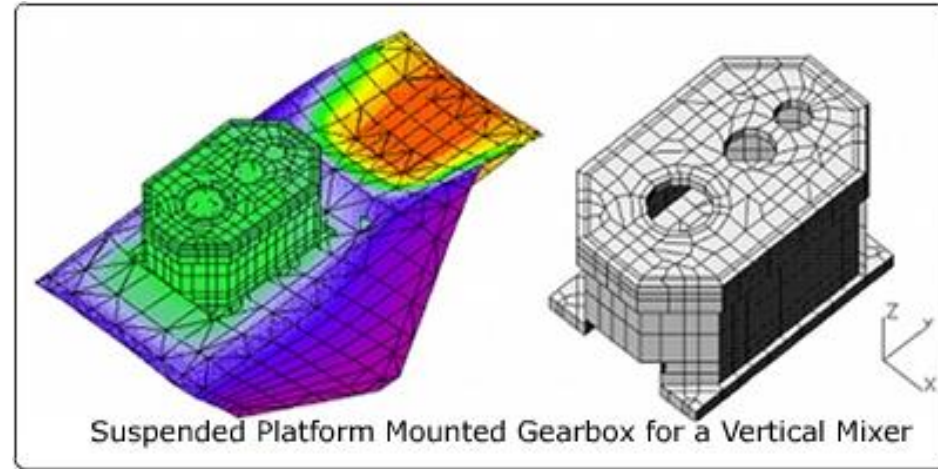

Grinding Mill
Structural
Deformation
and Effects
On Bearing
Performance
And Failure

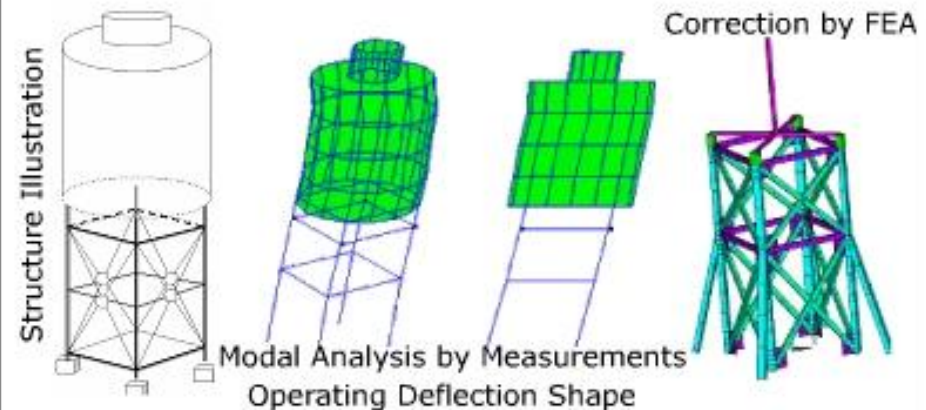
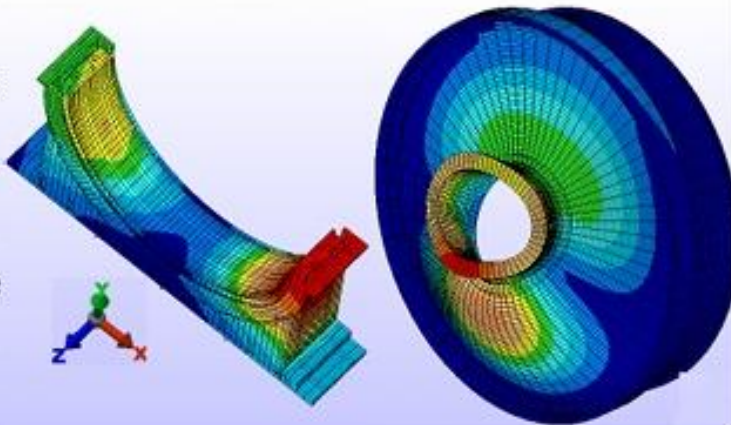



RBTS is a mechanical and structural engineering consulting firm specializing in **rotating machinery dynamics, bearings and bearing systems**, from design, performance prediction, trouble shooting and failure analysis. RBTS' principals offer engineering services to public, private, and government business sectors for a variety of services in rotating machinery dynamics, bearings design and analysis, and structural/mechanical engineering. RBTS specialists offer the following consulting services based on experience and know-how developed for over 40 years:

1- Analytical Vibration of Machinery & Support Structure

- Rotating Machinery Dynamics (Lateral, Torsional, Axial)
- Fluid-Film Bearings (Hydrodynamic, Hydrostatic & Hybrid)
- Rolling Element Bearings
- Seals (Mechanical Face Seals)
- Finite Element Stress and Dynamic Analyses
- Failure Analysis & Troubleshooting
- Retrofit and Design Audits
- OEM Interface and Witness Testing of Machinery

2- Vibration Measurements

- All Types of Vibration Measurements and Analysis for Excessive Vibrations, Mechanical Failures, Structural Failures, Torsional and Horsepower Issues
- Periodic and Online Condition Monitoring Programs
- Reliability and Production Limitations
- Equipment Design and Performance Deficiencies
- Ultrasonic Measurements
- Infrared Monitoring
- Oil Analysis

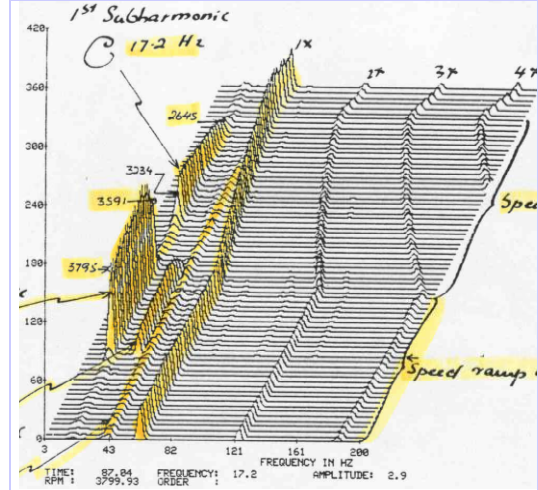
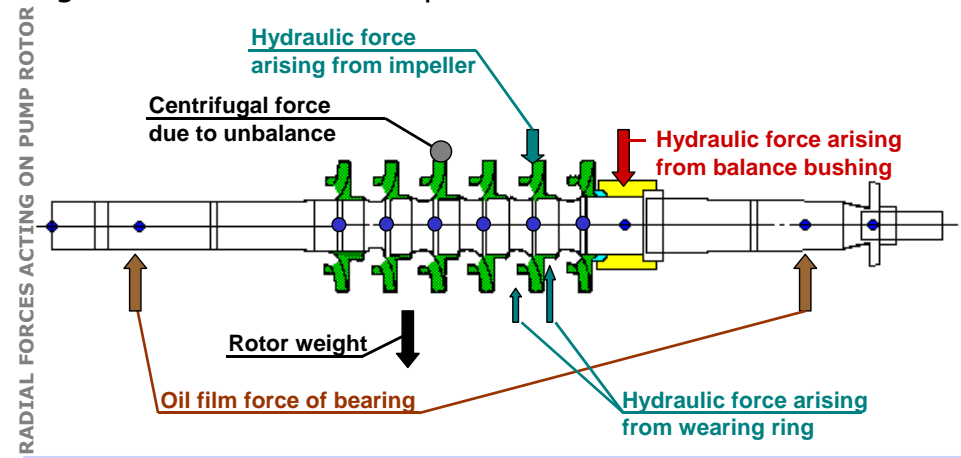

400MW Steam Turbine-Generator-Set High Sub-Synchronous Vibration Identification & Correction



3- Advanced Diagnostic Services

● Torsional Vibration

Experimental and analytical torsional modeling services for single and multi-branch systems. Telemetry technology with high speed data collection to accurately measure and analyze torque and torsional stresses in drive train systems.

● Structural Dynamics & Modal Testing

Detailed structural dynamic analysis combining Modal-Finite Element-Stress-Fatigue analysis is performed to assess potential failures resulting from stress cycles of vibration. Modal deflected shapes are captured experimentally and natural frequencies are determined to assess failure modes and recommend modifications to resolve problems.

● Reciprocating Equipment

Comprehensive vibration surveys are performed on reciprocating engine and compressor assemblies. Tri-axis data are acquired on all measurement points, scanned and compared to identify components exhibiting high vibrations and exceeding guideline limits. Advanced diagnostic techniques, Torsional and Modal Analysis, Operating and Real Time Base Deflection shapes are often used for in-depth analysis of machinery problems.



Torsional Strain Gages with Radio Telemetry on Motor Drive Extension

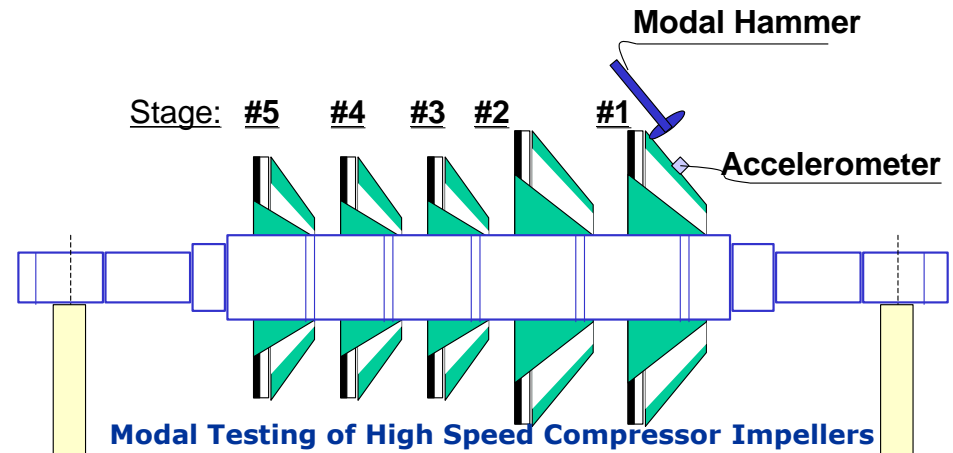



4- Reliability Services

- Reliability Program Maintenance Services
- Commissioning Services
- On-Site Corrective Balancing Services
- Temporary Data Collection Replacement Services
- Advanced Multi-Channel Data Acquisition Services
- Infrared Thermographic Surveys
- Airborne and Mechanical Ultrasonic Surveys
- Laser and Optical Alignment Surveys

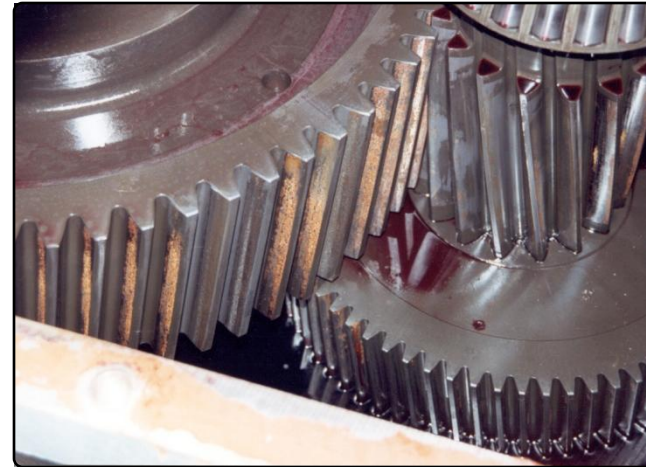

Identification
&
Correction
Of
Dynamically
Induced
Misaligned
Operation
Of a
Gearbox

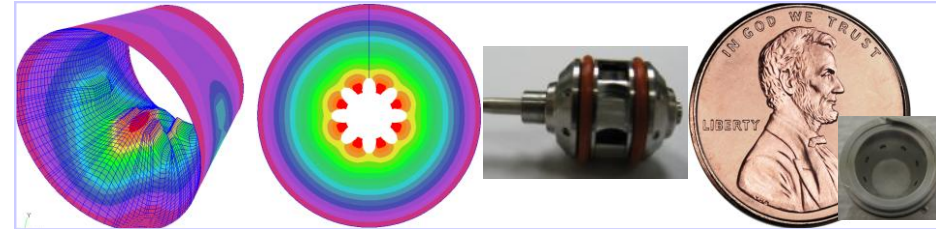

5- Training

- Field Balancing
- Basic Vibration Analysis
- Advanced Vibration Analysis
- Rotor Dynamics Modeling, Analysis, & Troubleshooting
- Bearings Design, Analysis, and Troubleshooting
- Technology Transfer





From the design of rotating components for NASA's space shuttle and space station, to the solution of an elusive vibration problem in a large industrial rotating machine, to the development of miniature pump rotating assembly and support bearings used for an artificial heart, **RBTS** is internationally recognized as an industry leader in providing **machinery rotor dynamics engineering services**.

With hundreds of successful projects completed, RBTS has developed unparalleled analytical and diagnostic tools and qualifications in the field of rotor dynamics. RBTS provides services to equipment users, packagers, as well as original equipment manufacturers. Our strength is based on our core technical proficiency, continuous improvement to our analytical tools, broad range of experience, and field service support.

Analyzed equipment range from fractional horsepower to over 1100 MW and vary in size from a small size turbine (0.10" in diameter, light weight, and speeds in excess of 250,000 rpm) to a large size 66,000 HP Multi-Stage Compressor with Synchronous Motor Drive

Typical analyzed equipment includes:

- Centrifugal Compressors
- Miniature Pumps
- Fuel Pumps
- Industrial Pumps
- Fans
- Mixers
- Gearboxes
- Generators & Power Generation Units
- Induction Motors (Fixed-Speed & VFD)
- Synchronous Motors (Fixed-Speed & VFD)
- Spindles (Machine Tools)
- Scanners
- Micro Turbines
- Turbines (Gas & Steam)
- Turbochargers
- Test Stands (Various Sizes & Power)

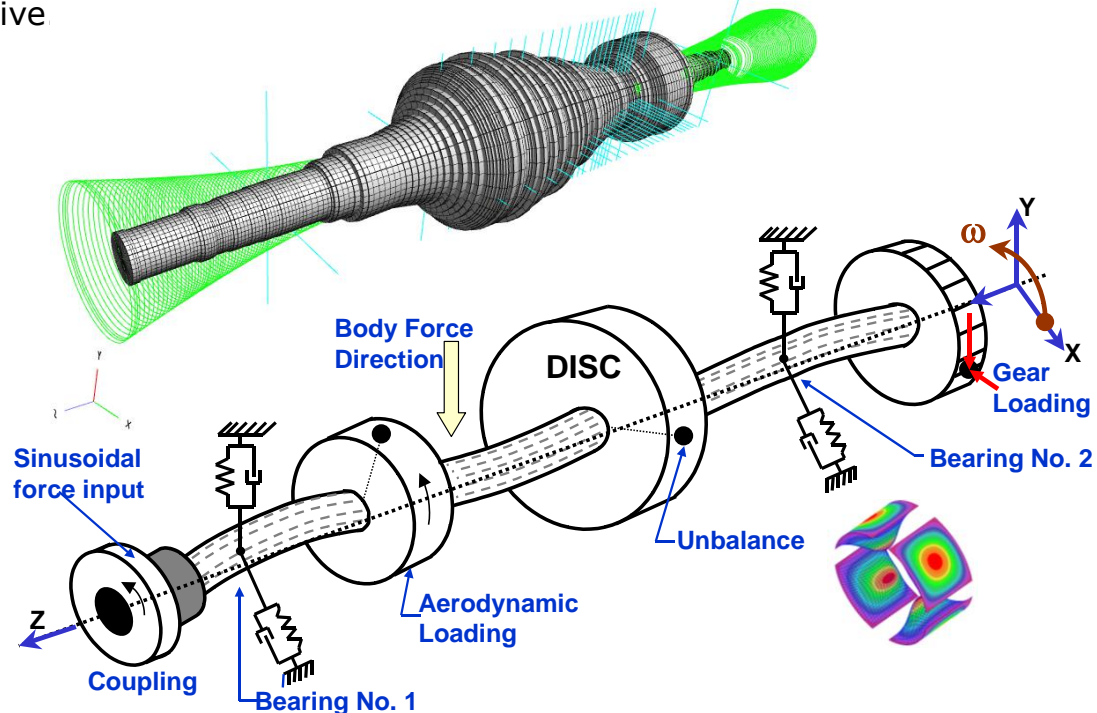

Our proprietary analytical software **ARMD** allows us to perform the full spectrum of rotordynamic simulations to comply with all **API, ISO, and DNV** standards.

Typical analyses include:

- Natural Frequency and Mode Shapes (damped and undamped)
- Stability Analysis (whirl & whip)
- Unbalance Forced Response (fixed & variable speed)
- Time-Transient Response

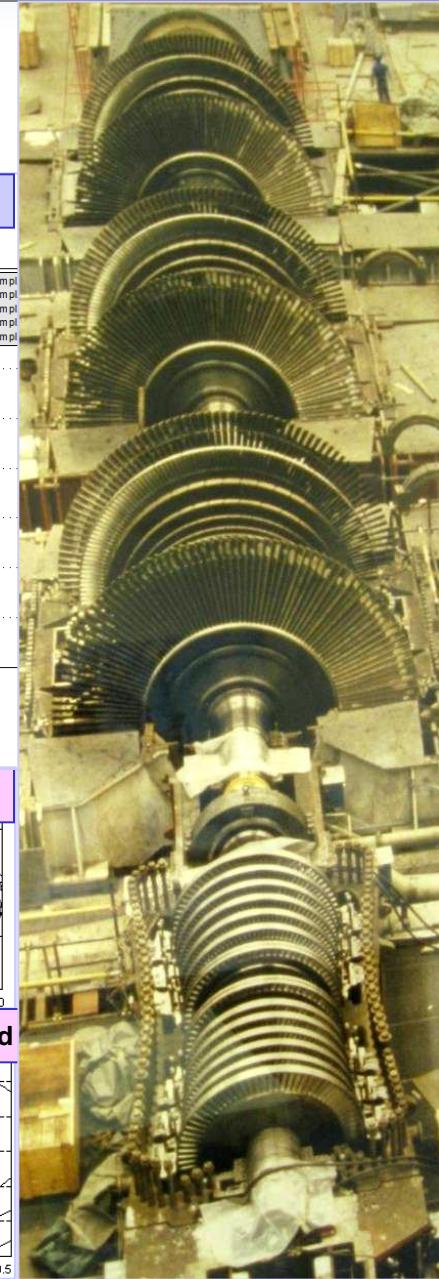
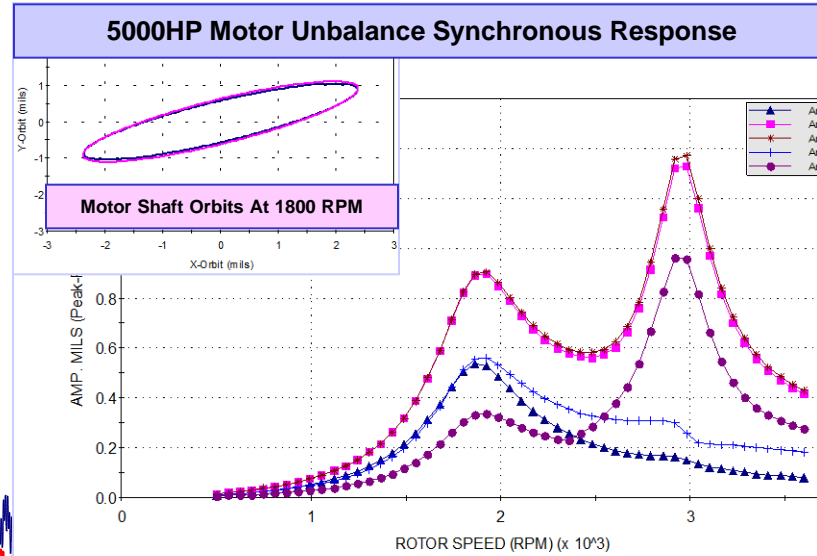

G:\ARMDWIN32\ROTLAT\Samples\TURB-GEN.ROI

300 MW turbine generator set for US Electric Power Utility.
Rotor Model-Pump Stub Shaft+HP+LP-1+LP-2 Turbines+Generator-Exciter.
Instability with Bounce/Bending Mode at LP1 and LP2 Turbine Bearings.

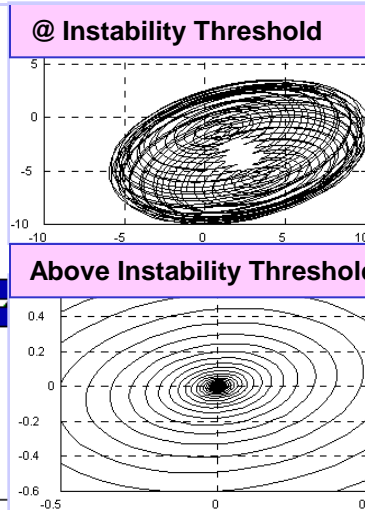
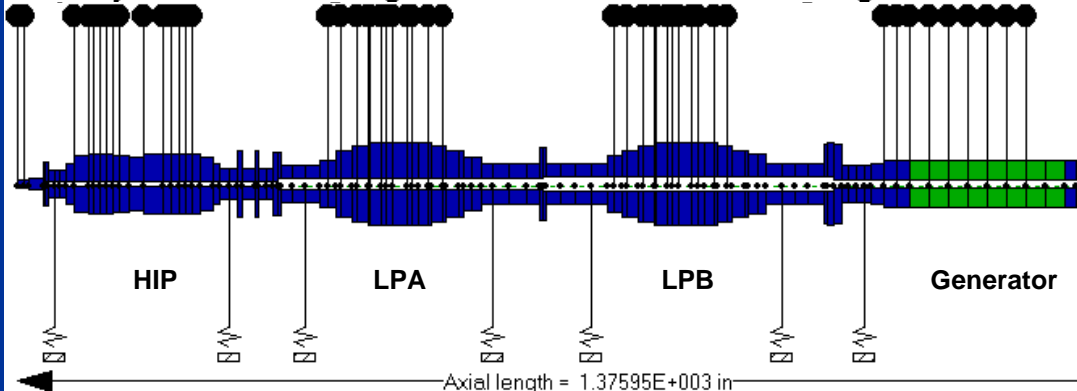



RBTS is internationally recognized as an industry leader in providing torsional vibration engineering services. With hundreds of successful projects completed, RBTS has developed unparalleled analytical and diagnostic tools and qualifications in this field of engineering. RBTS provides services to equipment users, packagers, as well as original equipment manufacturers. Our strength is based on our core technical proficiency, continuous improvement to our analytical tools, broad range of experience, and field service support.

Typical analyzed equipment includes:

Driven Components

- Reciprocating Gas Compressors
- Centrifugal Compressors and Pumps
- Screw Compressors
- Generators
- Industrial Fans
- Engines (Natural Gas & Diesel)
- Induction Motors (Fixed-Speed & VFD)
- Synchronous Motors (Fixed-Speed & VFD)
- Turbines (Gas & Steam)

Couplings & Other Devices

- Flexible Disc Pack Couplings
- Diaphragm Couplings
- Elastomeric Couplings
- Hydroelastic Couplings
- Fluid Drive Couplings and Clutches
- Viscous Dampers

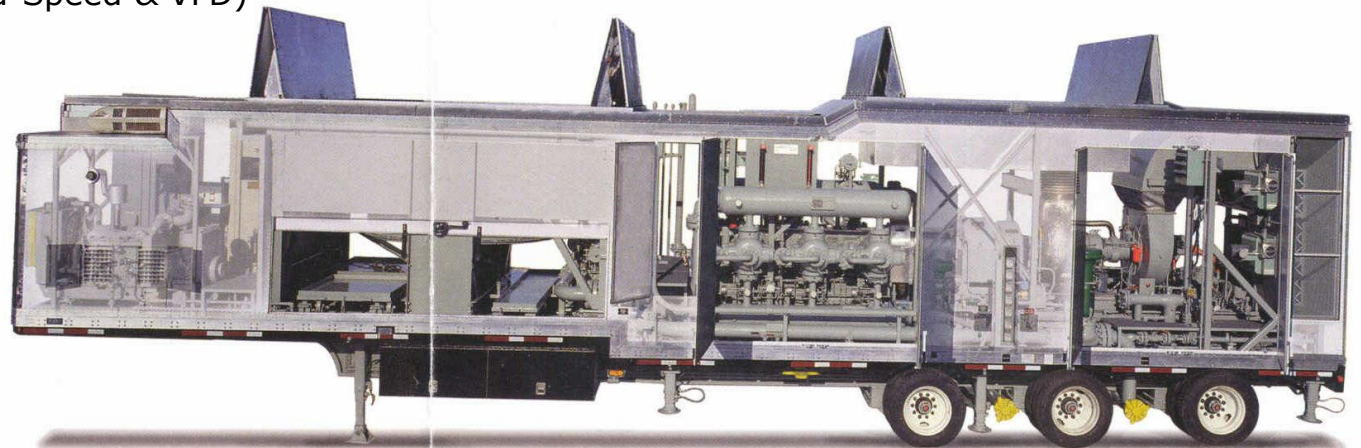

1,100 HP Solar Saturn Turbine Driver @ 22,250 rpm coupled to Westech gearbox driving Ariel JGE/6 Compressor @ 1013 rpm

Our proprietary analytical software **ARMD** allows us to perform the full spectrum of torsional vibration simulations to comply with all API, ISO, and DNV standards. Typical analyses include:

- Natural Frequency and Mode Shapes (Damped and Undamped)
- Steady-State Forced Response (Fixed-Speed & Variable Speed)
- Time-Transient Response
 - Synchronous Motor Startup
 - Reciprocating Compressor Startup and Emergency Stop
 - Electrical Fault Simulation (Short Circuit, Etc.)
 - Generic Events (Clutch Engagement, Etc.)
 - Nonlinear Behavior (Gear Backlash, Clutch Slip, Etc.)



2,000 HP JGT/6 Ariel Compressor with Waukesha 9390 Engine Drive

Synchronous Motor Start-Up Torque

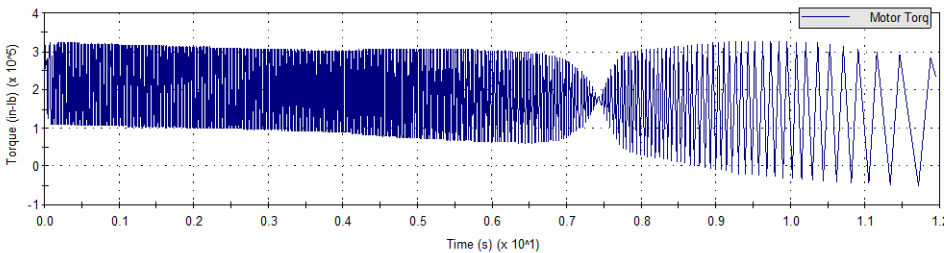

Compressor Shaft Start-Up Torque

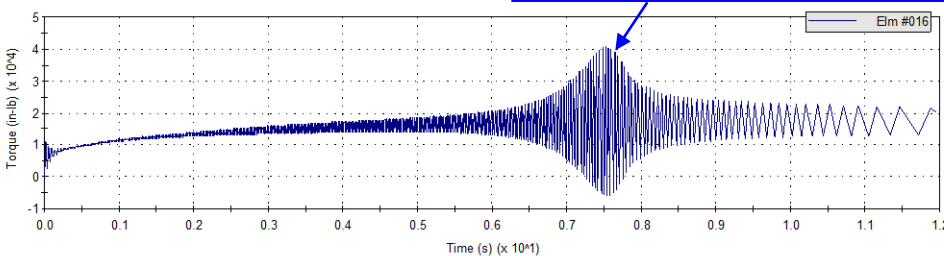

Drive Train Passing Through 1st Torsional Natural Frequency

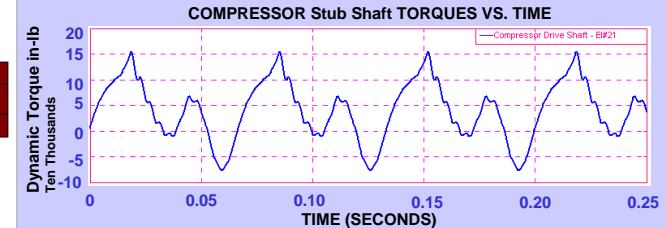
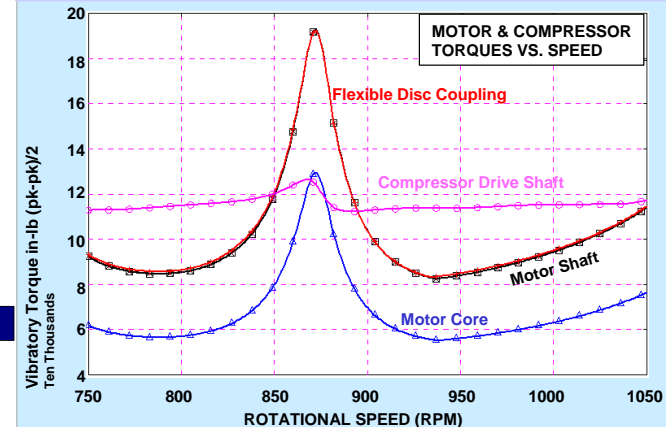
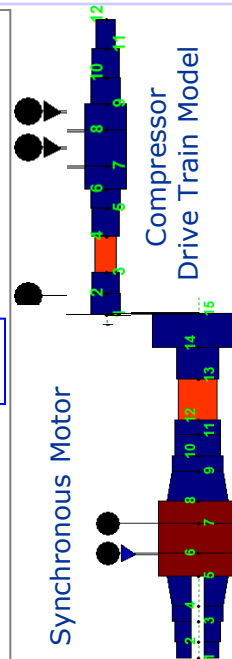



Services

Bearings

Bearings, the vital tribological element of rotating machinery is a specialty at RBTS. RBTS' principals with experience dating back to the 50's have an in depth knowledge and know-how in both fluid-film and rolling element bearings beginning with their fundamental principles of operation through advanced technologies for evaluating their operational performance characteristics and limitations.

From the design of water and blood lubricated bearings for artificial heart pumps, to the identification and solution of bearing failures in turbo-machinery, to the design of the world largest size bearings for the mining and hydropower generation industries, RBTS has been recognized internationally with unparalleled capabilities. Bearing designs smaller than 1mm operating above 10K rpm, 1" operating above 100K rpm, to large size 4.0 meter in diameter bearings have been successfully accomplished.

With many successful projects completed, RBTS has developed unparalleled capabilities and know-how that is offered to equipment manufacturers and users on a non-biased opinion. [Typical bearings design/analysis/trouble-shooting includes:](#)

- Fixed & Tilting Pad Geometries
- Journal, Thrust & Conical
- Incompressible Fluid (Oils, Hydraulic Fluids, Water, Blood, Etc.)
- Compressible Fluid (Air, Nitrogen, Oxygen, Etc.)
- Hydrodynamic, Hydrostatic, or Hybrid
- Full-Film, Mixed-Film, or Boundary Lubrication

Our proprietary analytical software allows us to perform a full spectrum of bearing evaluation to determine bearing acceptability based on performance characteristics such as:

- Operating Minimum Film-Thickness
- Flow Rate
- Heat Balance & Temperature Rise
- Dynamic Characteristics and Their Effects on Rotor Vibration
- Whirl and Whip Instabilities

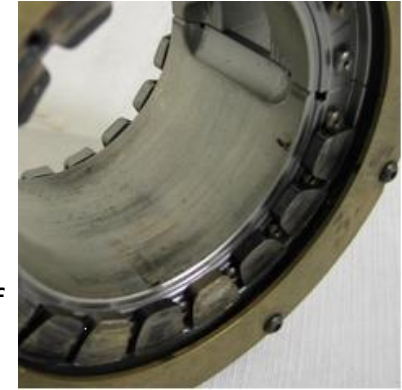

Fan Thrust Bearing Failure Analysis & Correction



Crusher Bearing Failure Analysis & Correction





A wide variety of structural/mechanical engineering services are available at RBTS. They include:

Finite Element and Specialized Analyses

- Linear and Non-Linear
- Static, Dynamic and Seismic
- Thermal (Steady-State and Transient)
- Cyclic Fatigue and Fracture Mechanics

Structural Analysis, Design and Evaluation

- Steel
- Reinforced Concrete
- Pre-stressed Concrete
- Masonry

Nuclear, Fossil and Petrochemical Plants

- Piping Systems and Supports
- Pressure Vessels and Tanks
- Seismic Analysis of Structures
- Seismic Qualification of Systems

Failure and Safety Analysis

- Fatigue Life Evaluation
- Failure Causes and Modes
- Safety Margins Determination
- Expert Witness





Services

Failure Analyses of Mechanical/Structural Components

Whenever practical, analytical predictions should be performed in concert with failure analyses to completely understand and successfully diagnose problems associated with the operation of rotating equipment. Over the years, RBTS has provided its customers with failure analysis support to address existing problems. In addition to using our own eyes, we routinely utilize both light and electron microscopy to facilitate our evaluations. When needed, we can arrange for specialized testing such as: material mechanical strength and fatigue, dimensional verification, and lubricant analysis

Common support areas where RBTS has provided failure analysis services include:

- Ball and Roller Bearings and Gearing
- Evaluations of Welds as Found in Rotors, Equipment Casings and Piping
- Torsional and Bending Fatigue of Drive Train Shafting
- Fretting Damage Due to Improper Interference Fits
- Fluid-Film Bearing Damage
- Damage to Coatings and Heat-Treated Wear Surfaces
- Service-Induced Damage on Lobed Pumps and Impellers
- Lubricant Evaluation

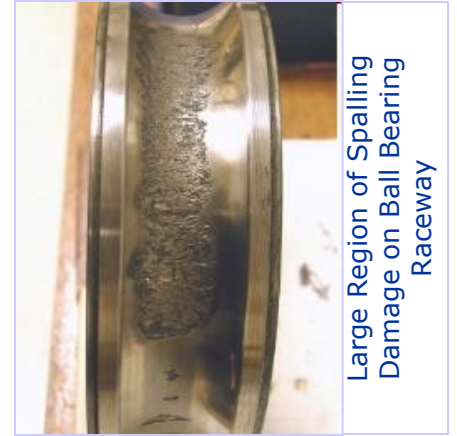

Large Region of Spalling
Damage on Ball Bearing
Raceway

FORENSIC INVESTIGATIONS
Torsional Failure in Motor
Drive End Shaft



Torsional Fatigue Crack
Motor Shaft

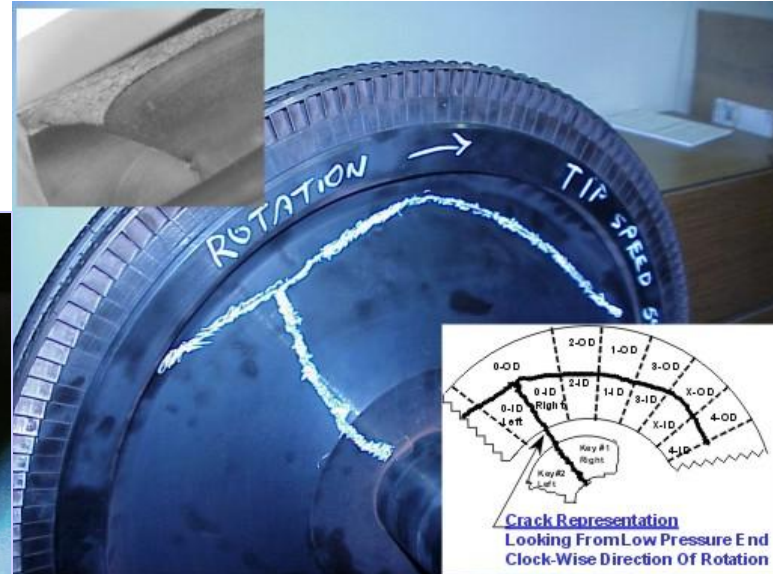
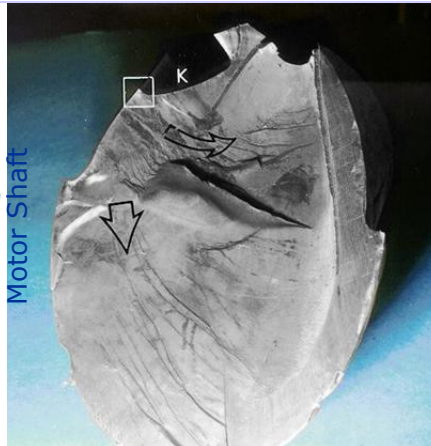

High cycle fatigue failure in steam turbine rotor
Failure analysis and design modification



At times, analytical predictions must be supplemented by field measurements to completely understand and successfully diagnose problems associated with the operation of rotating equipment. Field measurements are also routinely used to reinforce analytical predictions to assure the end user that the equipment is operating "as designed" and can be anticipated to provide trouble free service.

Over the years, RBTS has provided customers around the world with advanced field service engineering support to address existing problems, as well as to perform audits of new and revamped equipment. Our strength is based on our core technical proficiency and considerable experience working with, and at times reconciling differences between, analytically based simulation predictions and field measurement results. In most cases, RBTS provides field service support on a one time or, per incident basis. However, as needed, our staff can also design and provide periodic and online condition monitoring programs.

Common support areas where RBTS provides field measurement services include:

- Excessive Vibration and Shaking in Equipment Casing, Piping, Vessels, and Foundation
- Chronic Equipment Failures
- Reliability and Production Limitations
- Torsional Vibration and Power Throughput Issues
- Structural Problems Such as Improper Skid and Foundation Designs
- Excessive Pulsations in Piping Systems
- Establishment of Baseline Performance of New and Revamped Equipment

Services provided include the following areas:

- General Vibration (Linear Vibrations, Bearing Orbits, Etc.)
- Periodic and Online Condition Monitoring Programs
- Operation Deflection Shapes (ODS) Modal Analysis
- Torsional Vibration Measurements (Strain Gage, Encoder, Etc.)
- Ultrasonic Measurements and Infrared Monitoring
- Specification and Implementation of Customized Sensor Suites and Data Acquisition Strategies





Sample Diagnostic Equipment & Software

RBTS field services utilize the latest and most advanced diagnostic equipment and software available. A sample list of diagnostic equipment and software used in field services include the following:

Software	Type	Application	Copies
Iotech	Tomas	Continuous Data program	3
Iotech	wz_analyst	Modal, Transient Signal processing	3
Iotech	Rotate	Rotating Data aquaution and analysis	3
Iotech	Wave View	Data acquisition and analysis	3
Iotech	ez-Balance	Dynamic balancing software	3
Vibrat Technologies	Modal Pro	Modal analysis software	1
Vibrant Technologies	ODS Pro	Operating Deflection analysis software	1
Emmerson Process Management	RBMview	Vibration analyis/database program	3
Emmerson Process Management	Advanced Transient Software	Transient signal acquisition software	2
Emmerson Process Management	Fast Balance	Dynamic balancing software	2
Emmerson Process Management	MotorView	Motor analysis program	2
Emmerson Process Management	Nspector	Automatic fault dianostics program	2
DasyLab	DasyLab	Data acquisition and analysis	2
Windrock	6310 Recip analysis	Recroperating engine and compressor analysis program	3

No.	Equipment List
1	Iotech Zonic Book 16 Channel Simultaneous Data Acquisition System
2	Iotech Zonic Book 8 Channel Simultaneous Data Acquisition System
3	Iotech Model 516 Wave Book
4	Iotech WBK 16 Strain Gauge Signal Conditioner
5	Iotech WBK 14 Dynamic Signal Conditioner
6	CSI 2120 two channel analyzer
7	Instrunet 16 Channel Data Acquisition Systems – two units
8	Windrock model 6310 Reciprocating Engine Compressor Analyzer
9	Binsfeld Torque Track 9000 Torsional measurement system
10	IMI/PCB Modal Hammer Kits 12 lb Large Hammer 2.4 lb Medium Hammer 0.74 lb Small Hammer
11	Vibration Sensors – Accelerometers, Proximity Probes etc.
12	Dynamic and Static Pressure Transducers





Metrology:

In-house and on site metrology inspection and measurement services for components and equipment are available. These services are offered whether it is for a new component being validated against production drawings, fabrication specifications, and standards documentation, or a failed item being checked for fault. Access to the latest CMM and optical measuring systems, which provide the most precise measurements to measure complex geometries of impellers, volutes, bearings, etc., coupled with experience and knowledge on requirements of inspection combine to insure components under inspection meet their geometrical design constraints.

Mechanical Testing:

Equipment for mechanical testing is available to measure the strength and ductility of materials under various conditions of temperature, tension, compression and load. Mechanical properties testing include proof load, stress rupture, yield, bend, hardness and much more.

Metallurgical Evaluation:

Metallurgical analysis and services are available to detect internal and surface defects on test samples, reveal the microstructure or macrostructure of metal and determine conformance to required specifications. Metallurgical analysis services also provide insight into the cause of materials failures, when performance does not meet expectations. Photomicrographic examination and digital imaging with optical magnification up to 1000X are available and utilized for failure analysis of mechanical components on a regular basis.

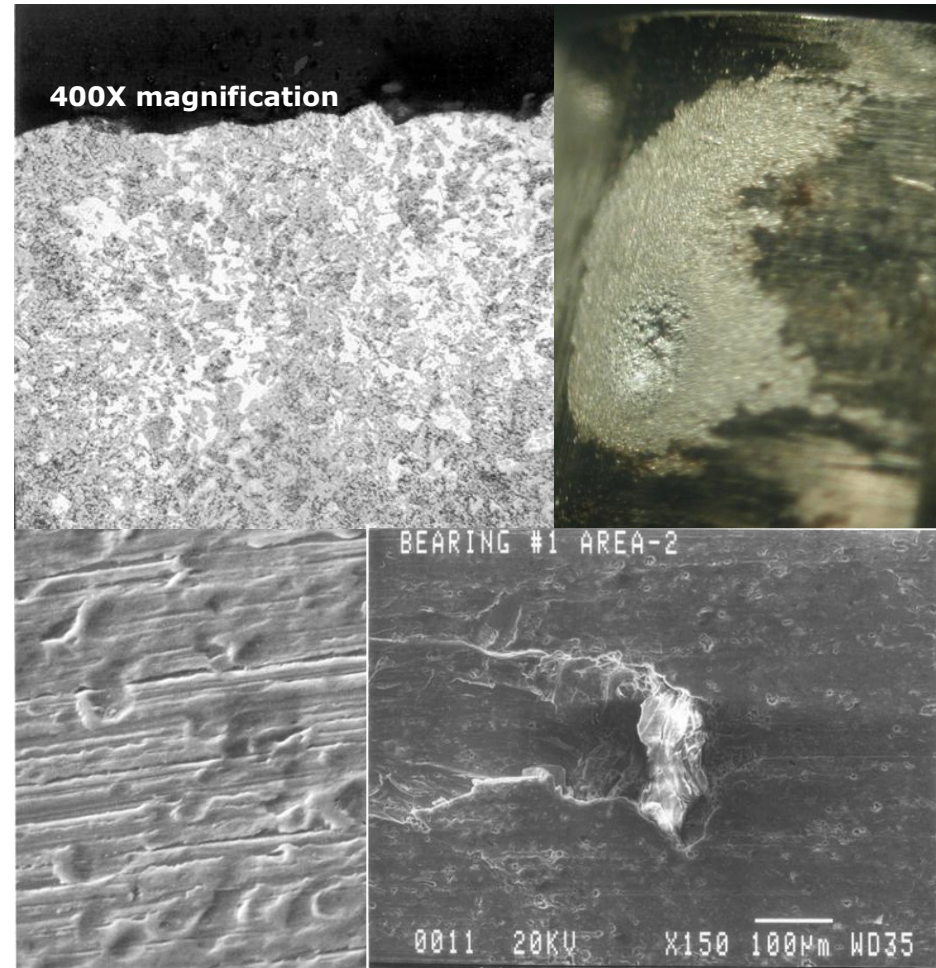

Around The World – Sample List Of Projects

1- **391MW Turbine Generator Set - High Vibration Root Cause Analysis & Correction**

Analysis of sub-synchronous vibrations occurring in a 391 MW Turbine Generator Set. Modeling and rotor dynamic simulation of the drive train and correction with appropriate bearing modification. Sheerness Power Station, ATCO Gas, Alberta, **Canada**

2- **Root Cause failure Analysis – Torsional Analysis**

Investigation of elastomeric couplings failure on Engine-Compressor drive train. Identify cause of problem while in the field, correct and verify solution. Sydney Gas Ltd., **Australia**

3- **Centrifugal Compressor Blades Failure Investigation – Modal Analysis & Correction**

Perform modal testing on compressor rotor and all blades on impellers. Identify cause of failure. Develop FEA model of impellers and design correction. Install modified impellers and confirm correction by testing. Siemens – **Singapore**

4- **Vibration and Structural Dynamic Analysis**

Perform vibration analysis and identify modal deflection shape of Engine-Gearbox-Pump Assembly. Recommend and implement modifications. IOC Ltd. Ahmadabad, **India**

5- **Failure Investigation – Torsional Analysis**

Perform lateral and torsional analysis and determine cause of failure of crank shafts. Analytical modeling and implementation of modifications retest and verify correction. Az-Zour Power and Sabiya Power Generation Plants, **Kuwait**

6- **66,000 HP Motor Compressor Assembly - Torsional Verification Testing**

Analytical study of synchronous motor-compressor drive train and dynamic performance verification by testing. Gas Plant, Delaware, **USA**

Around The World – Sample List Of Projects

7- **5000 HP Multi-Drive Unit High Vibration Problem Identification & Correction – Rotor Dynamics And Bearing Design Modifications**

Field vibration measurements of a multi-drive unit consisting of Murray Steam Turbine, Nuttall Gearbox, Westinghouse Electric Motor driving Cooper Centrifugal Compressor, and rotor dynamic evaluation coupled with bearings design modifications to eliminate experienced problems. Fibras Quimicas Plant, Monterrey, **Mexico**

8- **700MW SANXIA Hydroelectric Turbine Generator Set**

Bearings & Rotor Dynamic Evaluation Including Turbine Guide Bearing Design Modification for Stable Operation. Three Gorges Dam, Yangtze River, **China**

9- **Ball Mill Bearings Failure And Correction**

Ball mill bearings failure evaluation and design modifications including lubrication system capabilities to deliver required lubricant pressure/flow-rate. LCAL / Lycopodium, Makati city, **Philippines**

10- **Ship Thruster**

Sea water lubricated thrust Bearing design, evaluation, and implemented in BRUNVOLL Thruster units. Oslo, **Norway**

11- **Failure Investigation – Steam Turbine Repetitive Cracking Evaluation & Correction**

Field vibration measurements and balancing coupled with rotor dynamics, torsional vibration, and stress/fatigue evaluation of steam turbine. Recommended correction by shaft design modifications to shift critical frequency from operating speed range, which caused dynamic amplification leading to rotor cracking. Suncor Energy, Fort McMurray, Alberta, **Canada**

12- **MATIMBA Power Station Ball Tube Mills Bearings Failure Evaluation & Correction**

Evaluation and design modifications of hydrostatically lubricated cylindrical, spherical, and thrust bearings supporting MATINBA coal pulverizer mills. ESKOM, Johannesburg, **South Africa**