

Advanced
Rotating
Machinery
Dynamics

ROTLAT Version 6.0

**New
Release**

Rotor Dynamics – Rotor/Bearings/Supports Lateral Vibration Analysis

- ROTOR DYNAMICS (ROTLAT)
- Stability Analysis (ROSTAB)
- Unbalance Response (ROSYNC)
- Time Transient Response (RORESP)
- Critical Speed & Stability Maps (ROTORMAP)

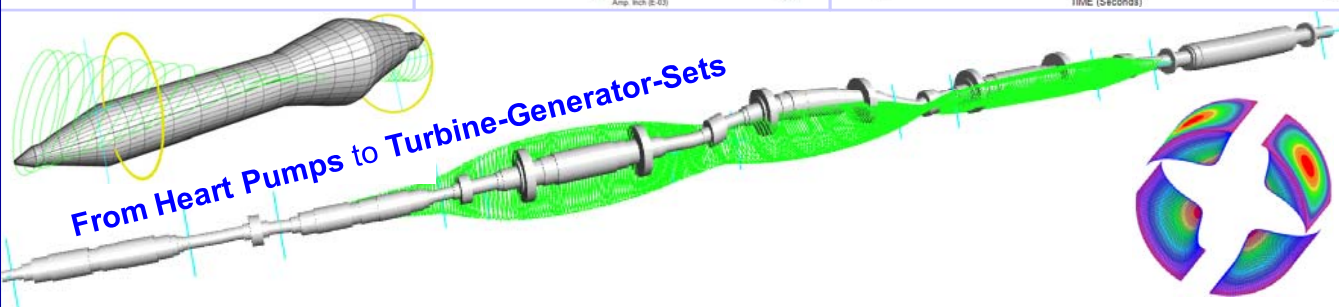
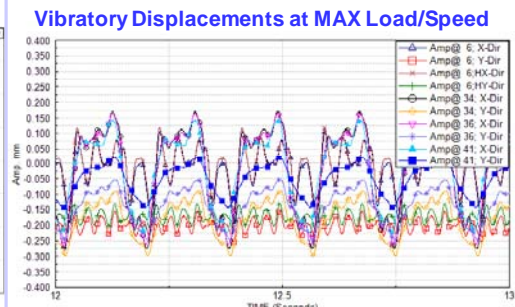
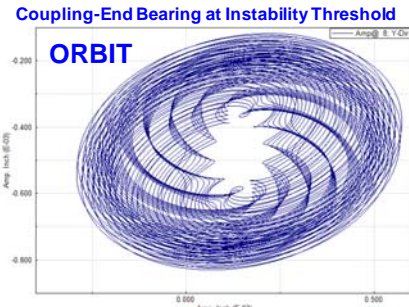
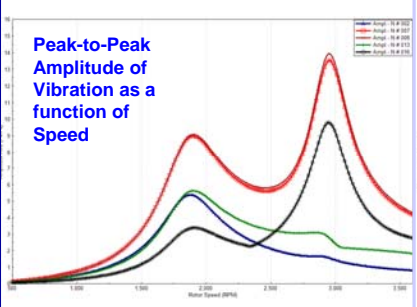

 **RBTS, Inc.**
Rotor Bearing Technology & Software
1041 West Bridge Street
Phoenixville, PA 19460, USA

Tel: 610-415-0412
Fax: 610-415-0413
Email: info@rbts.com
Web: www.rbts.com

ARMD™ V6.0

ROTLAT Package

The Worldwide Leader in Software for Rotating Machinery Dynamics

The rotor dynamics lateral vibration analysis package uses a finite-element based formulation, for performing damped and undamped **natural frequencies, mode shapes and stability** (ROSTAB & ROTORMAP), **synchronous unbalance response** (ROSYNC) and **non-synchronous time-transient response** (RORESP) of rotating machinery. The four sub-modules are integrated by ROTLAT's user interface. The user interface controls the sub-modules to provide a complete rotor/bearing system dynamic analysis environment integrating the rotating assembly with its support bearings, wear-rings, seals, aerodynamic effects, support structural flexibilities, etc.

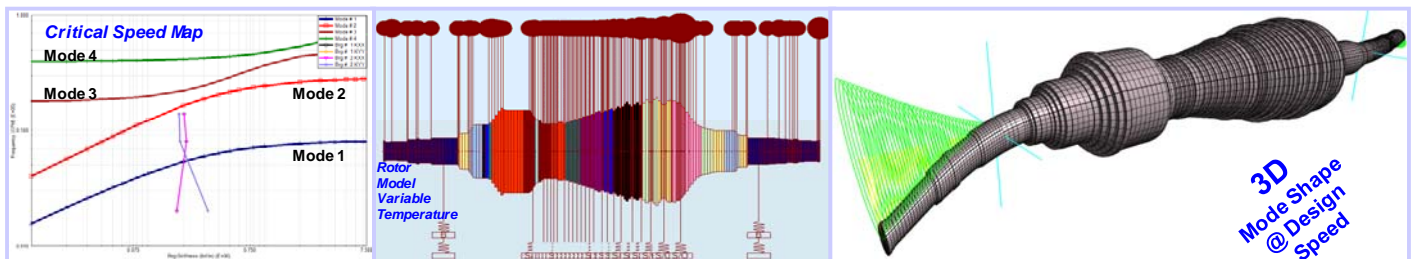

ROTLAT incorporates advanced modeling features and capabilities including the following:

- Rotor of various configurations: Solid, Hollow, Tapered & Stepped.
 - Shaft material damping.
 - Gyroscopic effects (discs with angular degrees of freedom).
 - Element geometry, stiffness diameter, or element stiffness.
 - Bearings of all types: Cylindrical, Conical, Tilting Pad & Rolling Element.
 - Bearing models linked to rotating assembly at any station.
 - Bearings vertical elevation for accurate bearings load computation.
 - Springs: wear-rings, seals, aero-dynamic effects, squeeze-film dampers, etc.
 - Springs models linked to rotating assembly at any station.
 - Bearings support systems; casing and foundations.
 - Static foundation/pedestal flexibility (mass, stiffness and damping).
 - Dynamic (frequency dependent) foundation/pedestal flexibility.
 - Discs: couplings, impellers, sleeves, etc.
 - Moment release (pin-joint) at shaft stations.
 - Multiple unbalance forces at any location and phase orientation along the shaft.
 - External excitations and body forces: sinusoidal, step, ramp and pulse type functions.
- *The release of RBTS' ARMD Version 6 Rotor Dynamics is a major milestone in the product's development history, rolling out a **completely new and improved** graphical user interface for the package with enhanced numerical capabilities and analysis features. The software's front end was redesigned with our customers' and industry's input to incorporate the most logical, efficient, and productive techniques to model and analyze complex rotor/bearing systems for lateral vibrations.*

ARMD™ V6.0 – ROTLAT Package

ARMD ROTLAT users will immediately see the improvements as element, shaft, and system data are presented in a flatter format, with key fields and analysis options readily visible and accessible from the main data entry screens. Engineering productivity to design models is vastly improved as shafts and systems can be easily imported from user-generated component template models. Furthermore, the ability to simultaneously run multiple instances of the program permits rapid side-by-side comparison of results.

By identifying new trends from industry standards, along with RBTS' involvement in turbomachinery standards revisions, new technical features were added to the software. Addition of equivalent element stiffness diameters, user specified stiffness for such elements as flexible coupling or disk plate, expanded user-defined forces application, better access to temperature dependent properties, seamless integration of modeled bearings and springs (such as wear-rings, seals, aerodynamic effects, squeeze-film dampers, etc.) all combine to provide more accurate modeling and better matching of analysis results to actual system empirical results.

New Enhanced Modeling, Usability and Technical Features:

- **Improved TAB layout.** Redesigned for more direct and faster access to data input locations and results. Important functionality is brought forward into the TAB structure, thereby eliminating the need to select from drop down or pop-up menu lists.

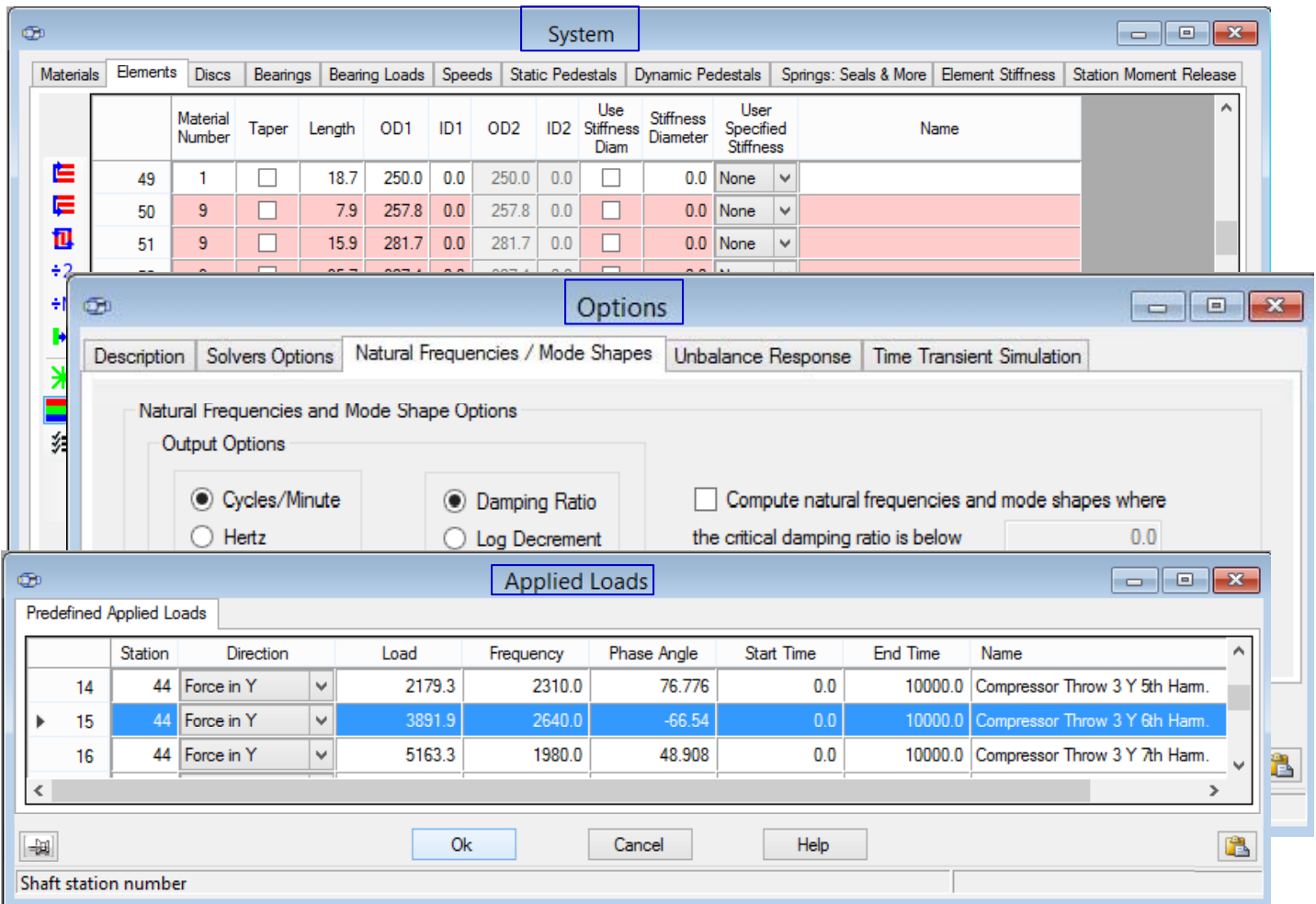

ARMD™ V6.0 – ROTLAT Package

➤ **Multiple instances of ROTLAT.** The newly developed package can now **open simultaneously multiple instances of ROTLAT**, so modeled shaft and components can be moved easily between different system models to allow fast, side-by-side comparison of model variations and analysis results. This functionality permits multiple instances of ROTLAT Version 6.0 or Version 5.8 to be accessible on your screens.

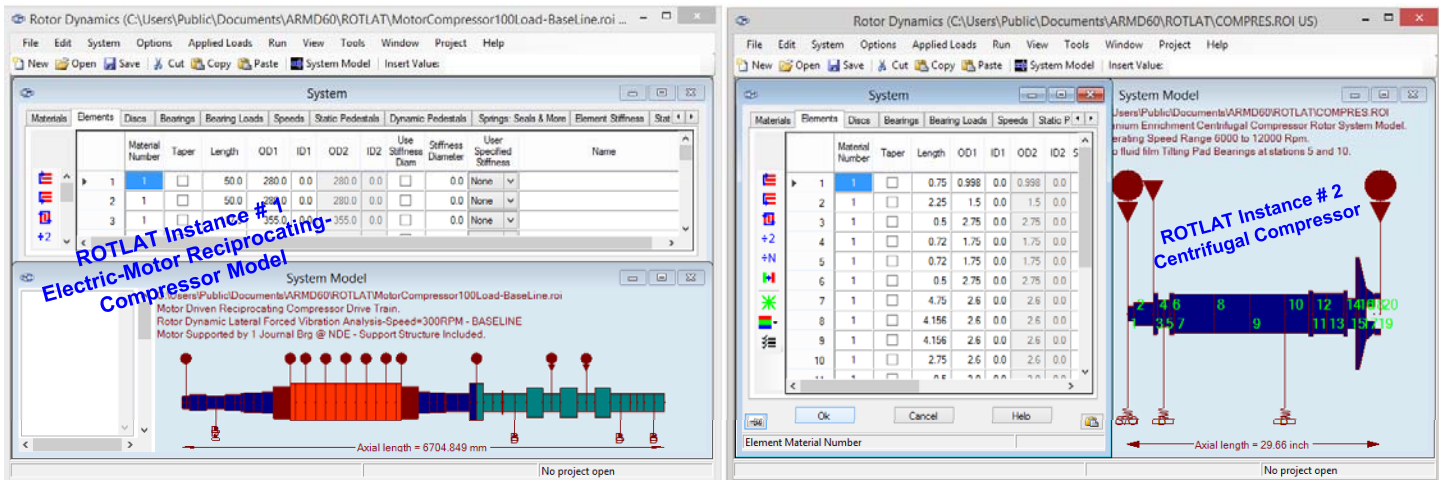

Many of the improvements incorporated into the ARMD ROTLAT Version 6.0 are specifically directed towards simplicity, increasing usability and increasing productivity as illustrated below:

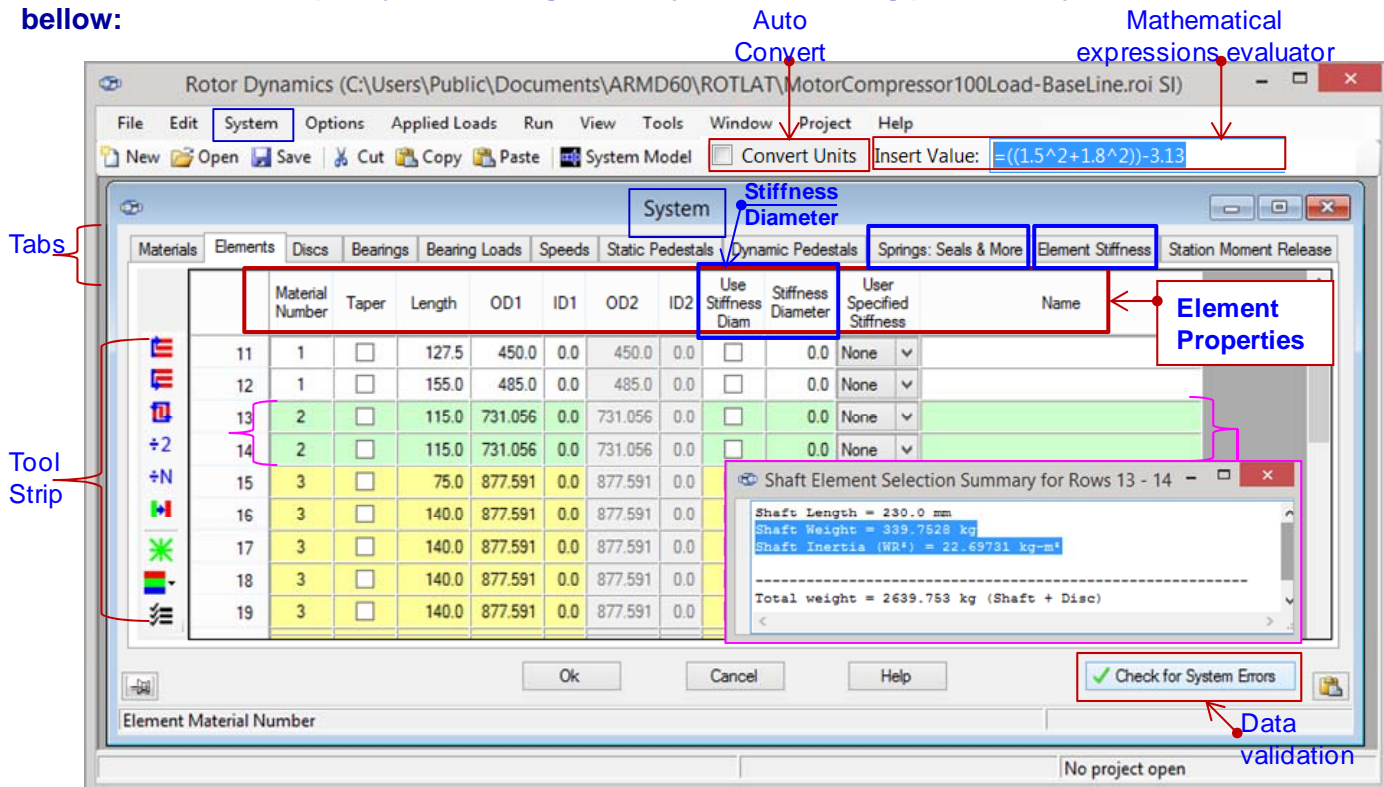

- | | | | | | | |
|------------|--|--|--|------------------------|--|----------------------|
| Tool Strip | | Move row Up | | Split Element | | Mark/unmark elements |
| | | Move row Down | | Divide into N elements | | Color rows |
| | | Reverse order of elements on the shaft | | Change material | | Get Summary |
| | | | | | | |

ARMD™ V6.0 – ROTLAT Package

- **Evaluate Mathematical Expressions.** When entering data to cells, data entry field has the ability to evaluate mathematical expressions, without having to launch a calculator app.
- **Whole Number.** Display for improved legibility, defaulting to scientific notation when required.
- **Auto Convert Units.** Automatically computes the units conversion when modeling a system with different components using mixed SI and English units. Example: You have a few inch dimensions to enter amongst hundreds of mm values, just check the box for auto conversion.
- **Automatic Cell Validation.** Performed at data entry time. The program now reviews data grids for incomplete, invalid, or nonsensical entries, providing an error flag and correction recommendation. This applies to mass-elastic data fields, user defined torques, and required solver data inputs.
- **Data validation error diagnostics** quickly walks user through any model input errors. A mouse click navigates the user to the next error found.
- **Row Tagging.** Row marking/tagging for quick identification and rapid recall, advantageous for multi-shaft systems with very large numbers of elements.
- **Round Function.** Round function for data entry fields is accessible from the Tools menu, and can be declared for all data fields.
- **Tool Strip/Bar and Buttons.** Replaces hidden right-click menus to provide enhanced visibility of functions and features.
- **Data Entry Grids.** All data entry grids can be open simultaneously for ease of model building.

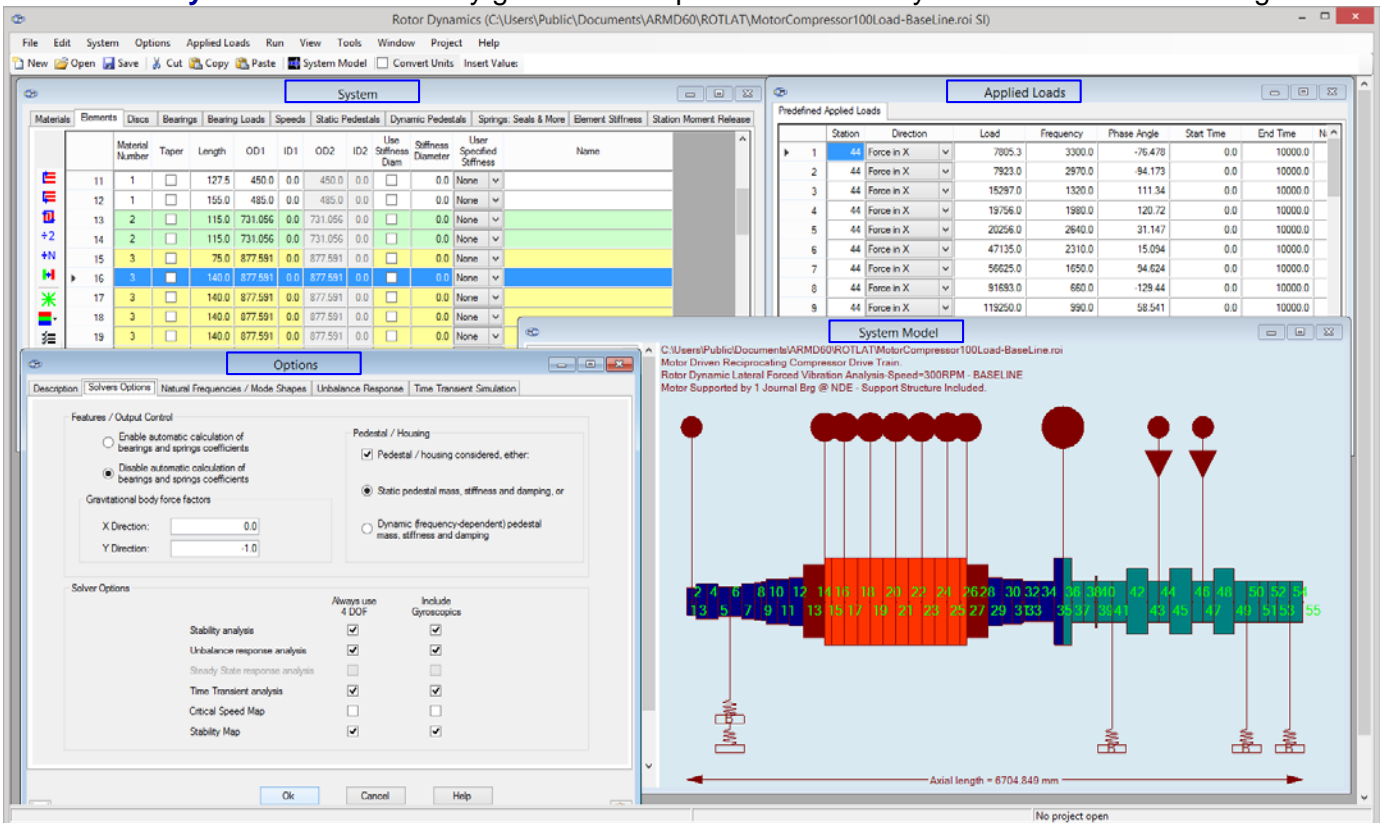
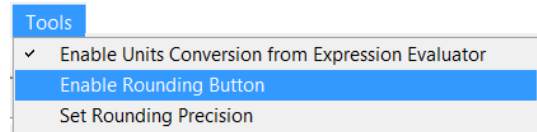

ARMD™ V6.0 – ROTLAT Package

- **Data Entry Menus.** All data entry menus are visible at the Grid Input page. Grids now feature selection check boxes and editing buttons where appropriate.
- **Shaft Material Temperature.** Material operating temperature is readily input and enabled, to capture the temperature dependent material properties and their effect upon rotating assembly dynamic characteristics. Particularly useful for shafts in high temperature applications like steam turbines, rolling mills or extruders.

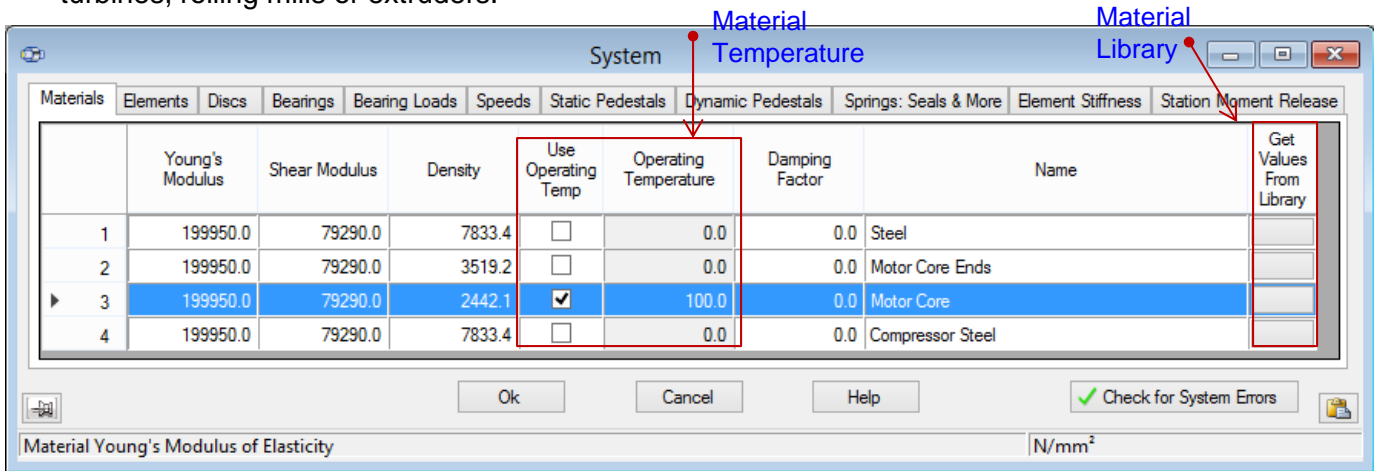

- **Stiffness Diameter** can be used to enter the equivalent mass-elastic properties of complex shaft sections, motor lamination stacks, shrunk on disks, etc. When selected, stiffness diameter is used to compute element stiffness while element geometry is used for computing element weight and inertia properties.
- **Discs & Disc Calculator.** Discs representing concentrated mass with/without inertia properties can be located at any station along the shafting system. A disc calculator is implemented in ROTLAT to compute weight, polar and transverse moments of inertia for user defined single or multiple disc geometries. Calculated weight and inertia properties are automatically placed in the appropriate cells in the Discs form.

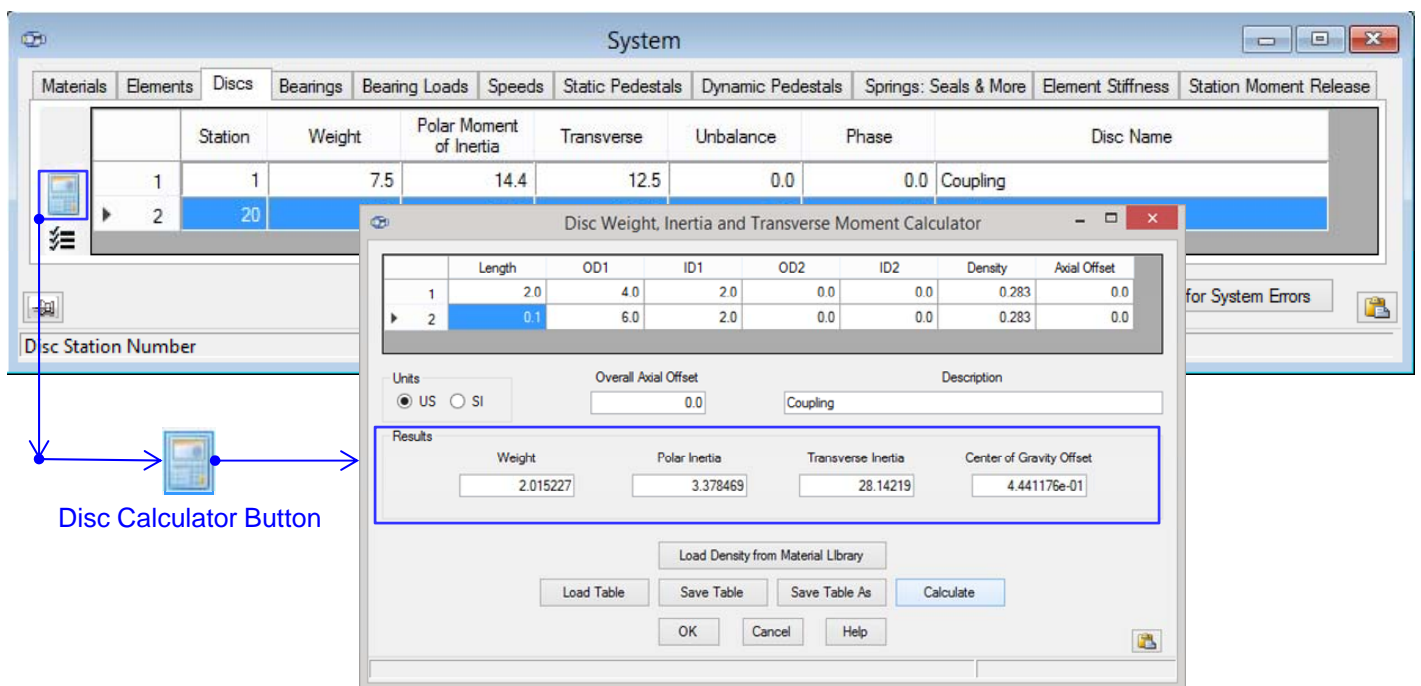

ARMD™ V6.0 – ROTLAT Package

- **Bearings** can be located at any station along the shafting system. Bearings are the fundamental elements supporting the rotating assembly, and any internally generated or externally applied forces and moments. Their dynamic properties (stiffness and damping coefficients) can be manually specified or automatically generated when bearing models are linked to specified stations on the rotating assembly.

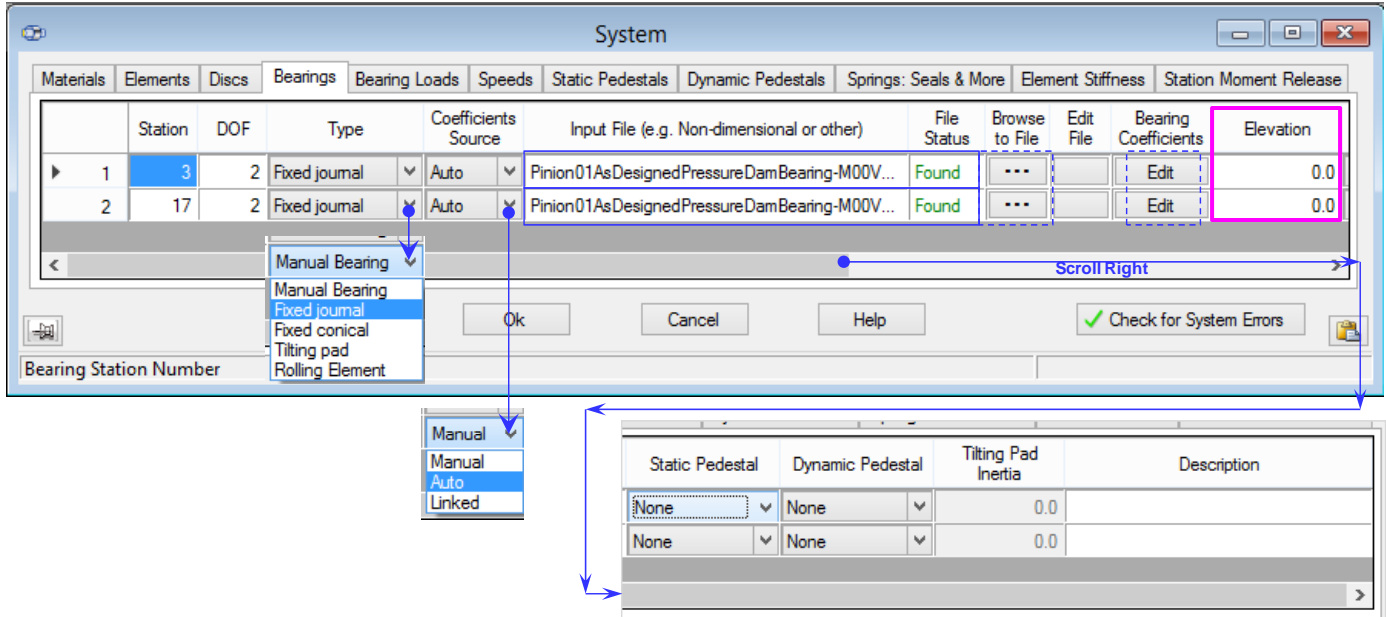

Typically, a bearing has two degrees-of-freedom (X and Y directions, Z being the rotational axis) which is the default setting. ROTLAT can accommodate any number of degrees-of-freedom such as **4x4** for bearings with moment stiffness (Rolling-Element bearings or Thrust bearings). Similarly, for Tilting-Pad bearings where pad pitch degree-of-freedom are to be considered (full stiffness and damping coefficients **NxN**) the size is set to 2 + number-of-pads).

- **Bearings Loads.** Bearing applied loads due to rotating assembly dead weight and/or externally applied forces and moments on the rotating assembly, can be automatically calculated or manually specified in the form. To automatically calculate bearing applied loads simply press the calculator button on the left side of the form.

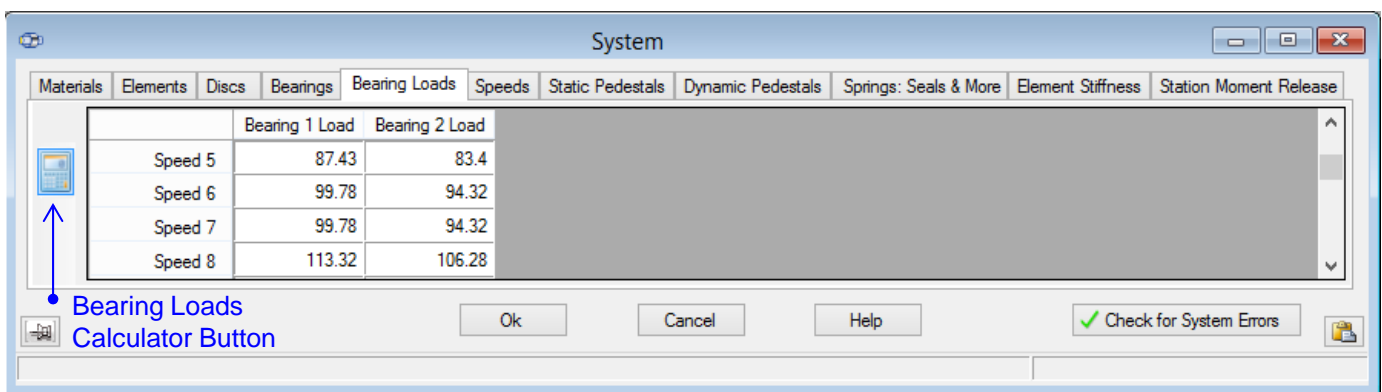

Bearing load calculations may-or-may-not consider dead weight load and externally applied forces/moments, but also will take **bearing elevation** into account to properly compute bearings load magnitudes and directions for each of the bearings supporting the rotating assembly. Bearings **Elevations** are influential when indeterminate supports are considered with three or more bearings such as those installed in multi-rotor power generating units.

ARMD™ V6.0 – ROTLAT Package

- **Speed Cases.** Many speed cases can be considered in rotor dynamic evaluation with ROTLAT. Speed cases entry and bearing dynamic coefficients viewing are designed for efficiency with copy and deep duplicate functions (all linked values are duplicated).

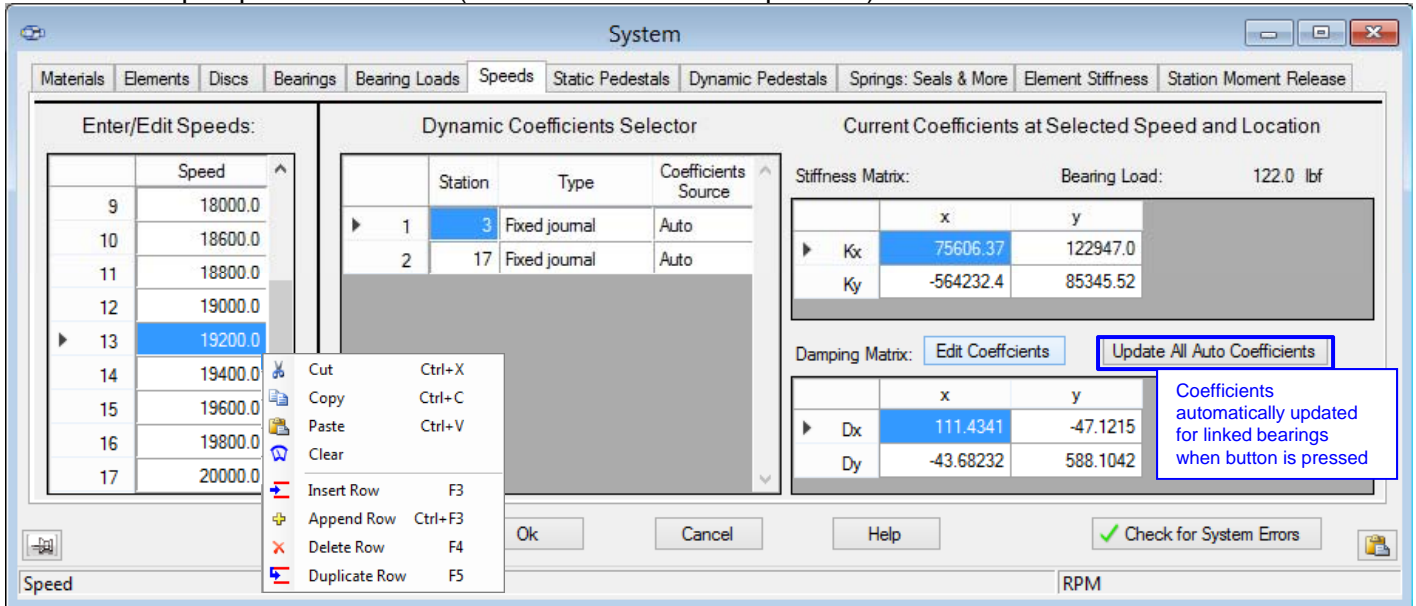

- **Static Pedestal.** Bearings support flexibility such as bearing housing, support structure, etc. can be considered in ROTLAT. These dynamic coefficients are normally defined in the horizontal X-direction and vertical Y-direction with their mass, stiffness and damping characteristics. Any defined static pedestal properties can be linked to any bearing in the system. ROTLAT not only accommodates these coefficients but also can accommodate cross-coupled coefficients as shown.

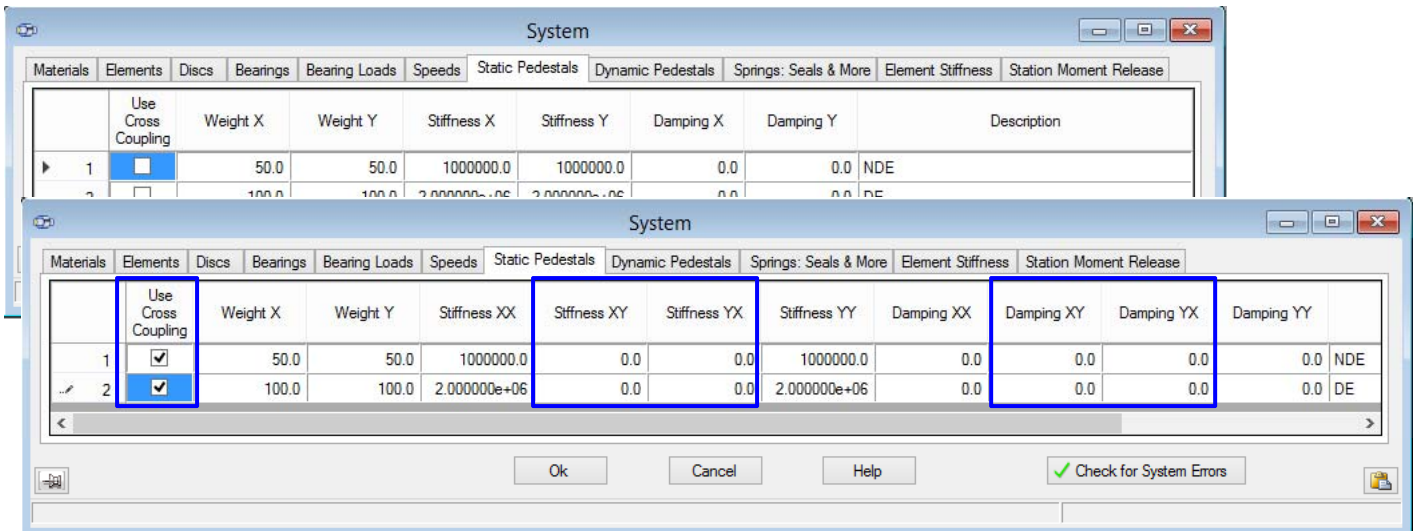

- **Dynamic Pedestal.** Similar to the static pedestal mentioned above, the dynamic pedestal defines the dynamic coefficients as a function of frequency bands calculated or measured in the field.

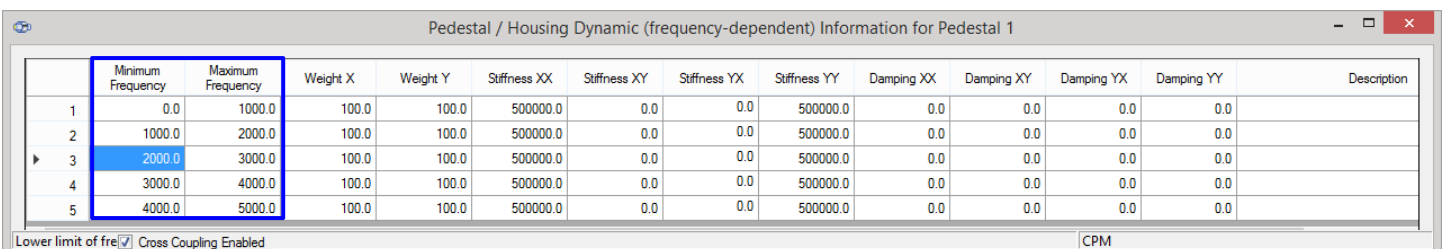

ARMD™ V6.0 – ROTLAT Package

- **Springs.** Provides the means to introduce dynamic characteristics (stiffness and/or damping coefficients similar to bearings) affecting the rotating assembly. This option permits the user to specify **dynamic effects** such as those arising from **Seals, Wear-rings, Impeller Aero-Dynamics, Impeller Hydraulics, Steam Whirl effects**, etc. that may be stabilizing or destabilizing forces on the rotating assembly. Their dynamic properties (stiffness and damping coefficients) can be manually specified or for some elements (shown below) automatically generated when these elements are linked to specified stations on the rotating assembly.

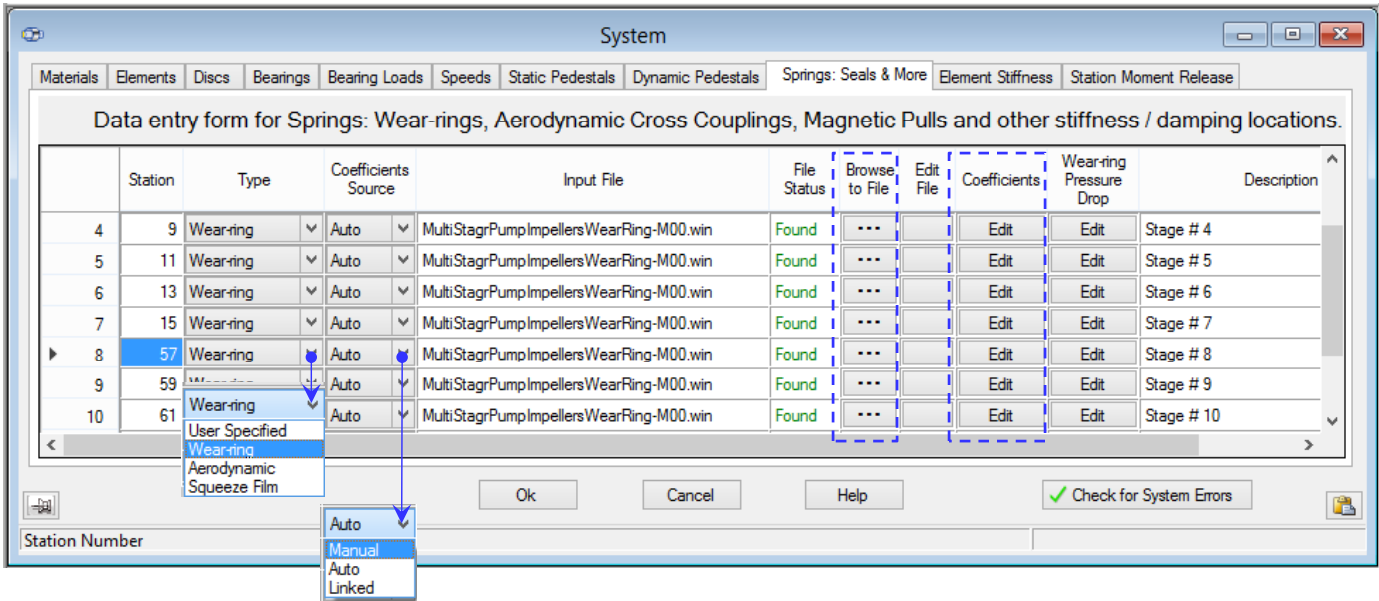

- **Element Stiffness.** The element stiffness feature (matrix tab shown below) permits user specification of elements stiffness matrices to be utilized in the shaft element form instead of being computed internally by the solvers from the specified element geometry. This feature allows the specification of element stiffness matrix for such elements as coupling, coupling connections, plate elements, discs, or any other flexible connection along the shafting system.

	X	αX	Y	αY
X	1,1	1,2	1,3	1,4
αX	2,1	2,2	2,3	2,4
Y	3,1	3,2	3,3	3,4
αY	4,1	4,2	4,3	4,4

Axisymmetric Non-tapered Element

	X	αX	Y	αY
X	$\frac{12EI}{L^3}$	$\frac{6EI}{L^2}$	$-\frac{12EI}{L^3}$	$\frac{6EI}{L^2}$
αX	$\frac{6EI}{L^2}$	$\frac{4EI}{L}$	$-\frac{6EI}{L^2}$	$\frac{2EI}{L}$
Y	$-\frac{12EI}{L^3}$	$-\frac{6EI}{L^2}$	$\frac{12EI}{L^3}$	$-\frac{6EI}{L^2}$
αY	$\frac{6EI}{L^2}$	$\frac{2EI}{L}$	$-\frac{6EI}{L^2}$	$\frac{4EI}{L}$

User Specified Element Stiffness Matrix

K _{xx}	K _{xxα}
2.905900e+07	1.452900e+07
K _{ααx}	K _{ααy}
3.004100e+07	-1.551200e+07

Edit the values above to produce the effective stiffness matrix shown below:

	x	αx	y	αy
x	2.905900e+07	1.452900e+07	-2.905900e+07	1.452900e+07
αx	1.452900e+07	3.004100e+07	-1.452900e+07	-1.551200e+07
y	-2.905900e+07	-1.452900e+07	2.905900e+07	-1.452900e+07
αy	1.452900e+07	-1.551200e+07	-1.452900e+07	3.004100e+07

- **Station Moment Release.** The station moment release permits specification of stations along the shafting system not to transmit moment forces across the station while transmitting full shear forces. This option lends itself to readily define a station reflecting shaft connections at universal joints,

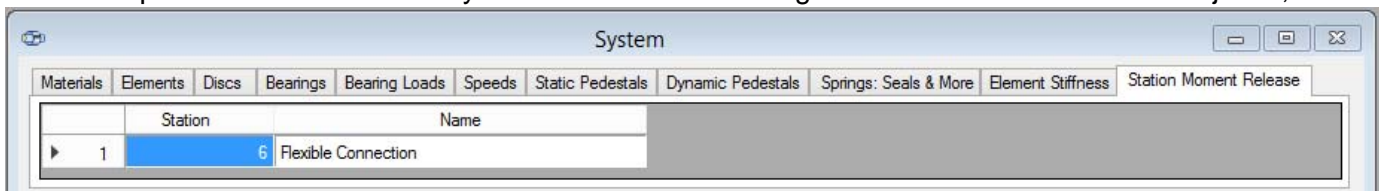

ARMD™ V6.0 – ROTLAT Package

➤ 2-D GRAPHICS MODEL.

Real-time graphics update of the 2-D image corresponding to numeric data input in data grids provides visual confirmation of model correctness while building system models.

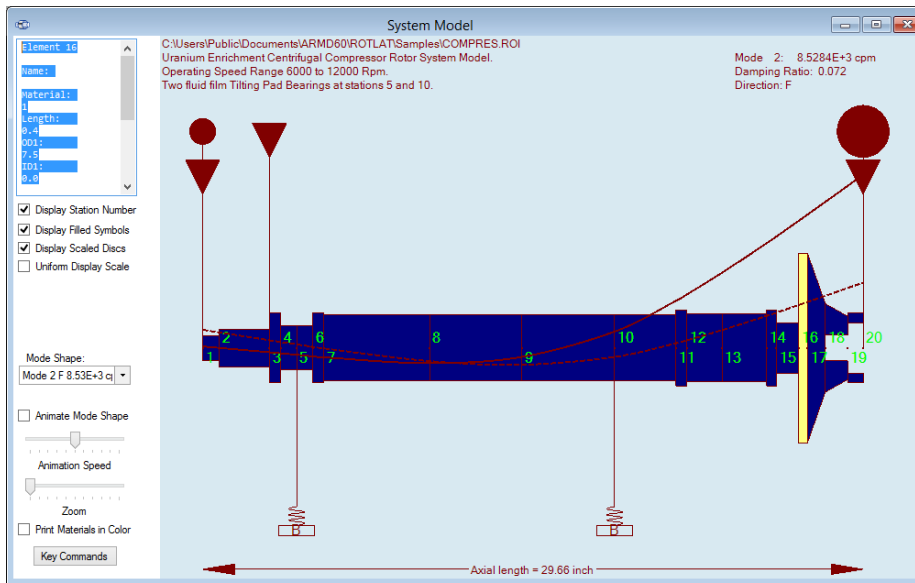

2-D Model auto resizing gives user the option to “fit-to-page” complete model. User can automatically view the model with the correct aspect ratio (Uniform Display Scale, shown below), thereby permitting rapid, visual model review. Shaft models can be **flipped from left to right** with a single button click.

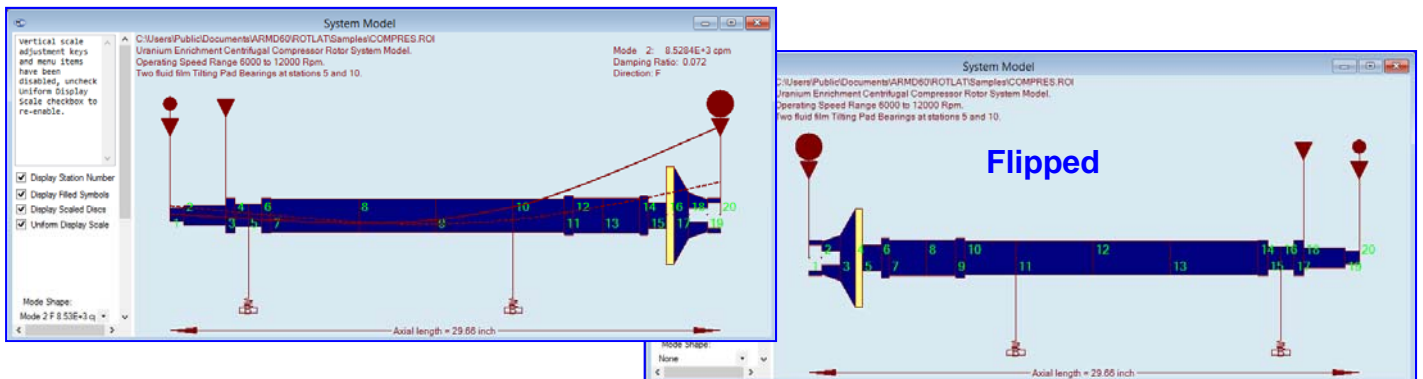

Interrogate an element in the 2-D Model Viewer to see all defining element data in a side-bar data window.

Element selection with control keys within the 2-D model viewer permits easy identification of particular cells within large models. This is useful for models with closely spaced thin elements.

Rotated view option for copying the 2-D model graphic to the clipboard.

Metfile enabled copy and paste of system models and graphics for better report graphics.

Tool panel has been added on the 2-D display window for enhanced graphics control and better visibility of display options.

ARMD™ V6.0 – ROTLAT Package

➤ **Text Output Viewer.** User selectable text output viewer that can be Word, Open Office Writer, Notepad, WordPad, or any other program which accepts text file input. Settings are specified in the ARMD Settings form from the help menu.

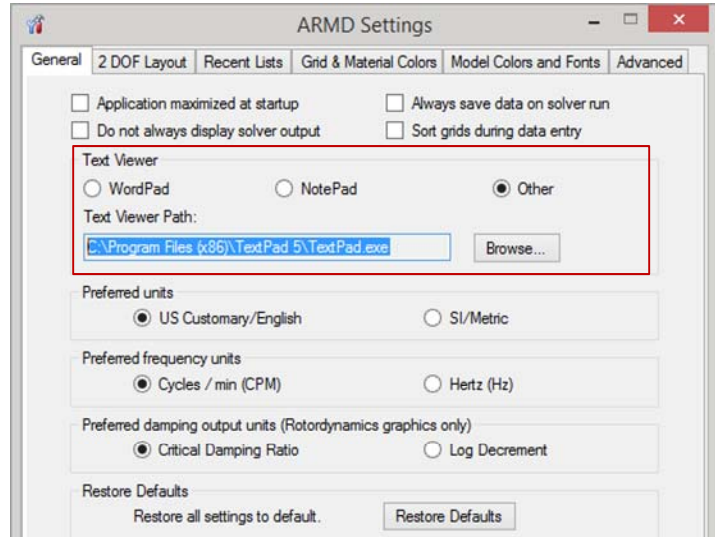

➤ **One-click Quick Chart.** This feature rapidly displays an X-Y graph of entered tabular data for visual verification of correctness. ARMD Graph software is still available for complete graphic analysis capabilities

➤ **Selectable Output Units.** Selectable Frequency Units between CPM or Hz, in accordance with the user's preference, or the industry standard format, can be set simply by checking a box in the options form. Also damping parameter (Damping Ratio or Log. Dec.) can be selected.

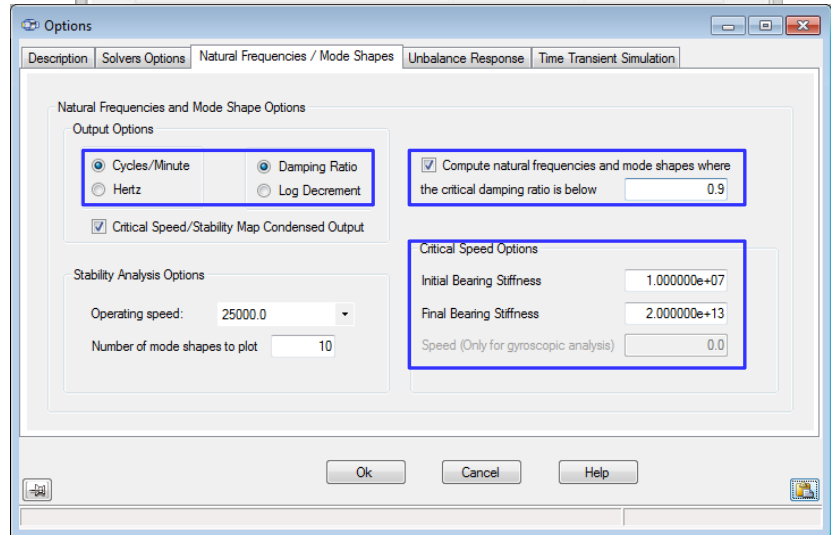

➤ **Damped Modes.** Users may eliminate graphical presentation of highly damped modes by simply checking a box and specifying damping ratio threshold.

➤ **Critical Speed Map Options.** Minimum and maximum support/bearing stiffness for critical speed map can be user specified and can include gyroscopic/speed effects.

➤ **Amplification Factors.** Amplification factors in accordance with API standards are computed for user specified stations by simply specifying the desired stations for this option.

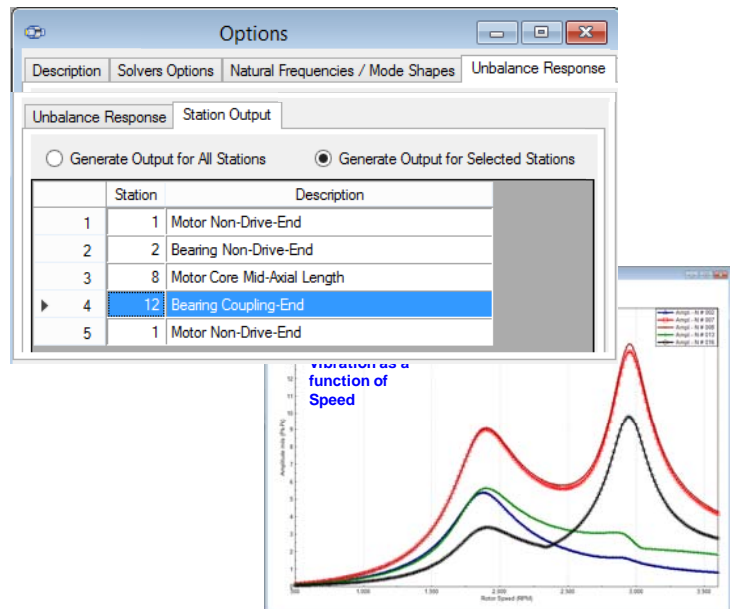

MOTOR.syo

AMPLIFICATION FACTORS FOR SPECIFIED ELEMENTS

MEASUREMENT TYPE	FREQUENCY (CPM)	AMPLIFICATION FACTOR	AMPLITUDE (mils Pk-Pk)
SHAFT STATION - Motor Non-Drive-End			
Y-AXIS	1870.9	4.31	4.531
Y-AXIS	1886.4	3.96	1.873
Y-AXIS	2914.6	6.92	1.449
MAJ. AXIS	1870.9	4.30	4.797
MAJ. AXIS	2945.7	9.21	1.817
SHAFT STATION - Non-Drive-End Bearing			
X-AXIS	1870.9	4.27	5.014
Y-AXIS	1886.4	3.99	2.235
MAJ. AXIS	1870.9	4.22	5.367
SHAFT STATION - Motor Mid-Axial Spinn			
Y-AXIS	1886.4	3.91	8.123
Y-AXIS	2945.7	10.08	13.926
MAJ. AXIS	1902.0	3.54	9.092
MAJ. AXIS	2945.7	9.79	13.935
SHAFT STATION - Drive-End Bearing			
X-AXIS	1902.0	3.79	5.520
Y-AXIS	2930.2	8.67	3.628
MAJ. AXIS	1902.0	3.64	6.000
SHAFT STATION - Coupling / Drive-End			
X-AXIS	1902.0	3.35	3.320
X-AXIS	2976.9	6.27	3.762
Y-AXIS	2945.7	10.40	9.090
MAJ. AXIS	1902.0	3.40	3.384
MAJ. AXIS	2945.7	10.31	9.812

ARMD™ V6.0 – ROTLAT Package

NATURAL FREQUENCY, MODE SHAPE & STABILITY

- Natural frequencies & mode shapes
- Damped and undamped simulation
- Stability parameters (damping ratio, logarithmic decrement)
- Rotor orbit direction (forward/reverse precession)
- Critical speed map
- Stability map / Campbell diagrams
- Bearing reaction forces
- Shaft weight, deflection, centerline slope, shaft moment, shear, & fiber stress diagrams

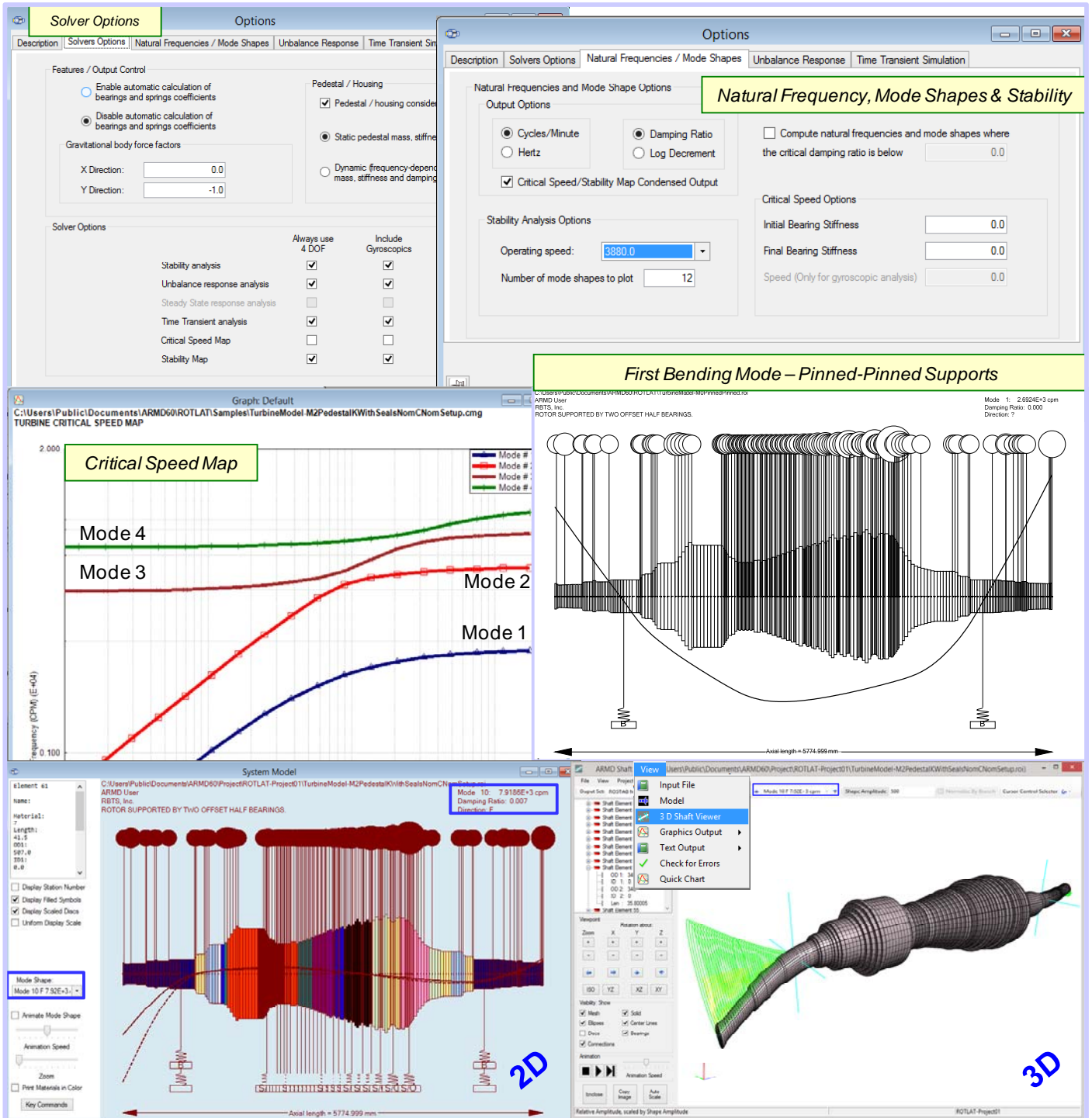

ARMD™ V6.0 – ROTLAT Package

Gear Box Pinion Shaft Rotor Dynamic Analysis - Speed 12,500-22,500 RPM.
Supported on Two Pressure Dam Bearings, Radial Clearance=0.00325", and
Dam Step Height=0.020". Lubricated by ISO 32 Oil Supplied @ 140 Deg.F.

High Speed Pinion

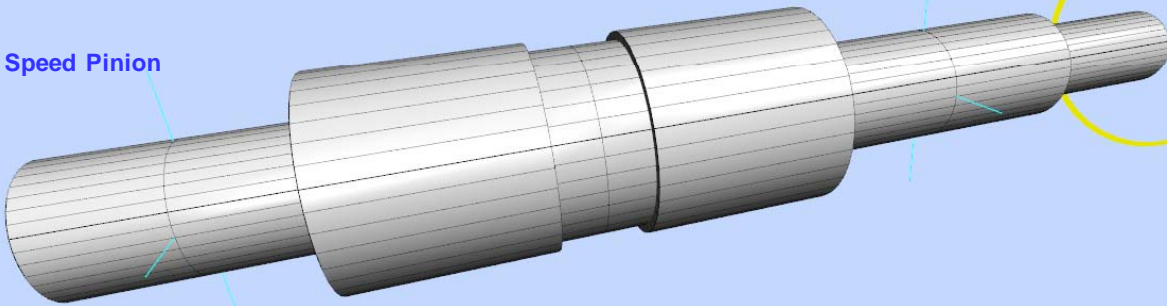

Campbell Diagram - Natural Frequencies & Stability

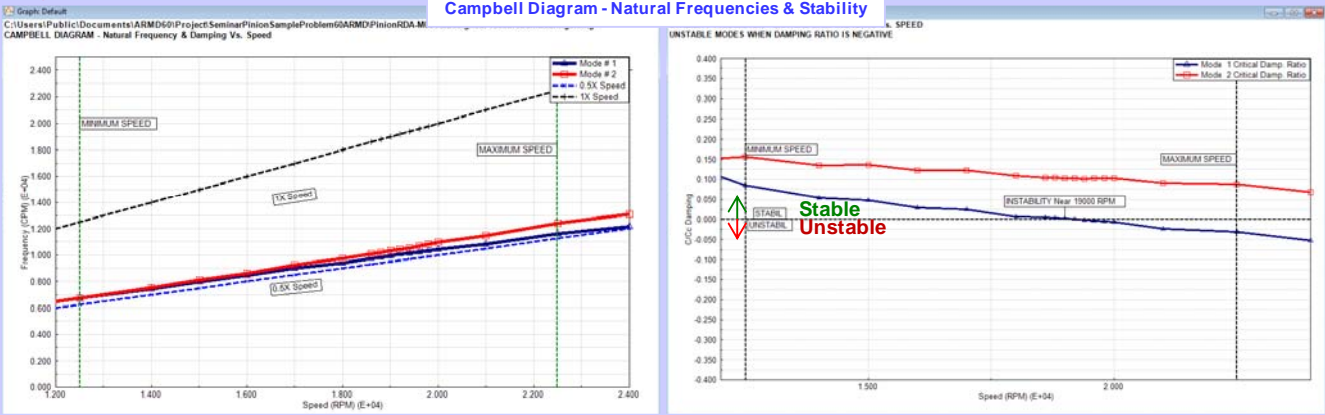

Graph: Default

C:\Users\Public\Documents\ARMD60\ROTLAT\Samples\TurbineModel-M2PedestalKWithSealsNomCNom Setup.stg

2D Graphics – Motor Lowest Eight (8) Natural Frequencies Modes of Vibration

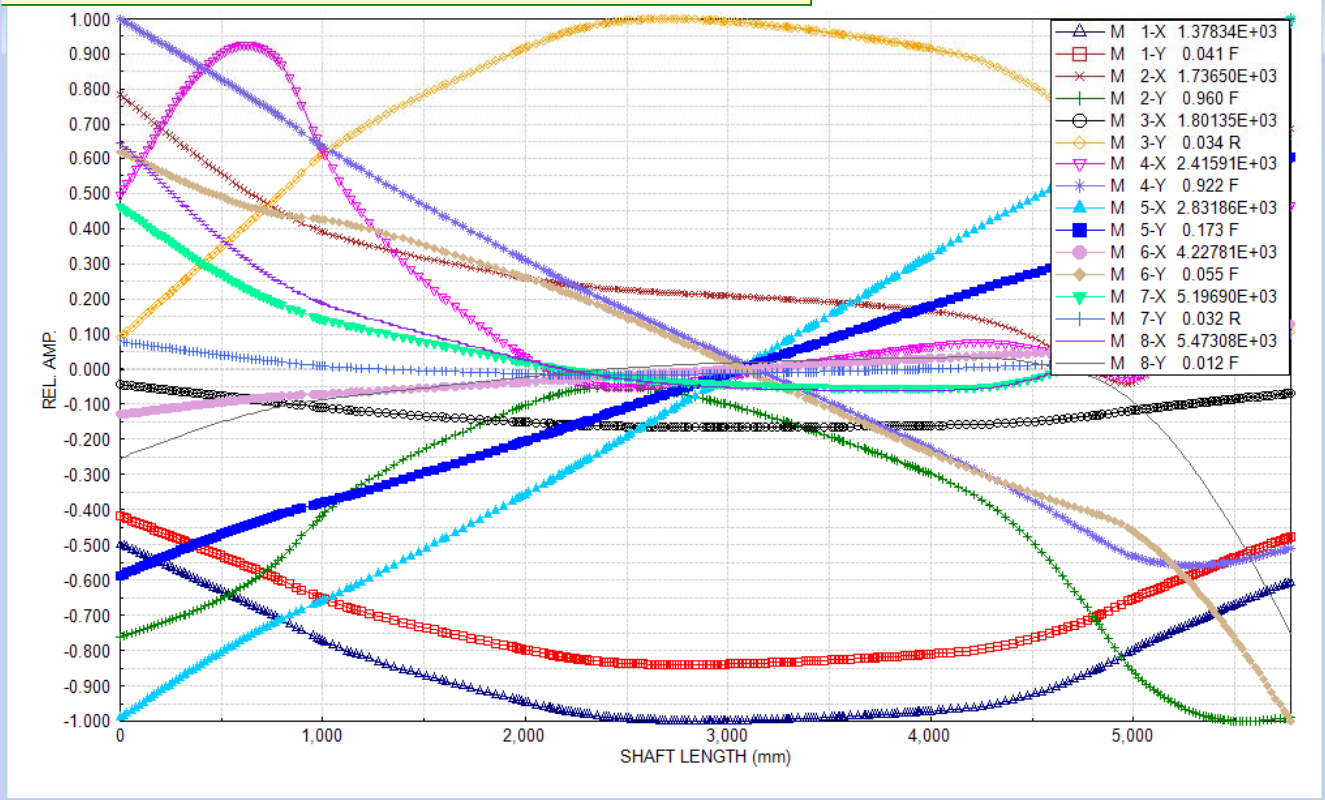

ARMD™ V6.0 – ROTLAT Package

UNBALANCE RESPONSE (Synchronous response)

- Multiple unbalance planes/forces
- Magnitude and phase (Bode plot)
- Dynamic forces and moments
- Vibratory amplitudes and orbits
- Forces and moments transmitted to bearing and foundation
- Foundation vibratory amplitudes
- API Amplification factors

Synchronous Unbalance Response

Compute unbalance response over the range of speeds shown here:

Initial speed: 500.0 RPM
 Intermediate speed: 1800.0 RPM
 Final speed: 3600.0 RPM
 Number of speed increments: 100

Motor Rotor Model – Unshaded

Peak-to-Peak Amplitude of vibration as a function of Speed

MEASUREMENT TYPE	FREQUENCY (CPM)	AMPLIFICATION FACTOR	AMPLITUDE (mils Pk-Pk)
SHAFT STATION – Motor Non-Drive-End			
X-AXIS	1870.9	4.31	4.531
Y-AXIS	1886.4	3.96	1.873
Y-AXIS	2914.6	6.92	1.449
MAJ. AXIS	1870.9	4.30	4.797
MAJ. AXIS	2945.7	9.21	1.817
SHAFT STATION – Non-Drive-End Bearing			
Y-AXIS	1870.9	4.27	5.014
Y-AXIS	1886.4	3.99	2.235
MAJ. AXIS	1870.9	4.22	5.367
SHAFT STATION – Motor Rotor Mid-Axial-Span			
Z-AXIS	1886.4	3.91	8.123
Y-AXIS	2945.7	10.08	13.926
MAJ. AXIS	1902.0	3.64	9.092
MAJ. AXIS	2945.7	9.79	13.935
SHAFT STATION – Drive-End Bearing			
X-AXIS	1902.0	3.79	5.520
Y-AXIS	2930.2	8.67	3.628
MAJ. AXIS	1902.0	3.64	6.000
SHAFT STATION – Coupling / Drive-End			
X-AXIS	1902.0	3.35	3.320
X-AXIS	2976.9	6.27	3.762
Y-AXIS	2945.7	10.40	9.090
MAJ. AXIS	1902.0	3.40	3.384
MAJ. AXIS	2945.7	10.31	9.812

5000 Horsepower Electric Motor Analysis
 Normal Operating Speed = 1800 (RPM). Two Fluid-Film Journal Bearing.
 Bearing data is generated with the bearing module JURNBR.

3D Graphics – Dynamically Deflected Rotor at Critical Speed of 2945 rpm
 Animation available for enhanced viewing.

ARMD™ V6.0 – ROTLAT Package

TIME-TRANSIENT RESPONSE (Non-Synchronous)

- Gravitational and external forces: Multiple sinusoidal, step, ramp, pulse and unbalance
- Vibratory amplitudes time history
- Rotor orbits
- Dynamic forces and moments
- Dynamic stresses
- Transmitted forces and moments
- Pedestal vibratory amplitudes

Options

Time Transient Control Options

Perform Time Transient Response using these features:

- Disc Unbalance
- Predefined Applied Loads
- Gravitational Body Forces
- Continuation run

Compute time transient response at: RPM

Number of time steps:

Time step interval for integration: Seconds

Requested Stations and Directions for Output

Station	X Amplitude	Y Amplitude	X Rotation	Y Rotation	X Housing Amplitude	Y Housing Amplitude
1	<input checked="" type="checkbox"/>	<input checked="" type="checkbox"/>	<input type="checkbox"/>	<input type="checkbox"/>	<input type="checkbox"/>	<input type="checkbox"/>
2	<input checked="" type="checkbox"/>	<input checked="" type="checkbox"/>	<input type="checkbox"/>	<input type="checkbox"/>	<input checked="" type="checkbox"/>	<input checked="" type="checkbox"/>
3	<input checked="" type="checkbox"/>	<input checked="" type="checkbox"/>	<input type="checkbox"/>	<input type="checkbox"/>	<input type="checkbox"/>	<input type="checkbox"/>
4	<input checked="" type="checkbox"/>	<input checked="" type="checkbox"/>	<input type="checkbox"/>	<input type="checkbox"/>	<input type="checkbox"/>	<input type="checkbox"/>
5	<input checked="" type="checkbox"/>	<input checked="" type="checkbox"/>	<input type="checkbox"/>	<input type="checkbox"/>	<input type="checkbox"/>	<input type="checkbox"/>

Applied Loads

Station	Direction	Load	Frequency	Phase Angle	Start Time	End Time
5	44 Force in X	20256.0	2640.0	31.147	0.0	10000.0
6	44 Force in X	47135.0	2310.0	15.094	0.0	10000.0
7	44 Force in X	56625.0	1650.0	94.624	0.0	10000.0
8	44 Force in X	91693.0	660.0	-129.44	0.0	10000.0
9	44 Force in X	119250.0	990.0	58.541	0.0	10000.0

9500 HP Motor Driving Reciprocating Compressor

C:\Users\Public\Documents\ARMD60\Project\MotorRecipCompressor-SampleCase\MotorCompressor100Load-BaseLine.roi

Motor Driven Reciprocating Compressor Drive Train.

Rotor Dynamic Lateral Forced Vibration Analysis-Speed=300RPM - BASELINE

Motor Supported by 1 Journal Brg @ NDE - Support Structure Included.

Axial length = 6704.849 mm

Compressor Excitation Forces At Normal Operating Conditions

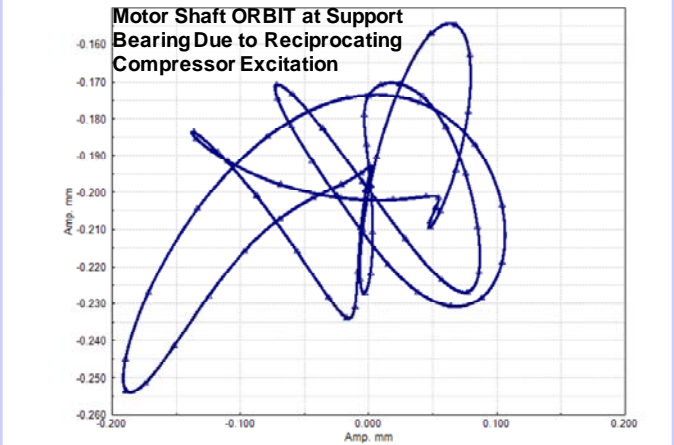
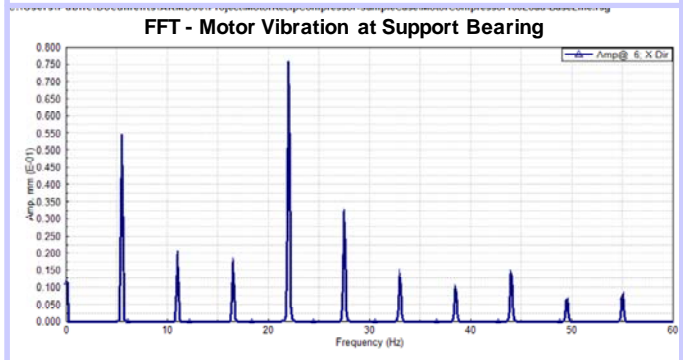
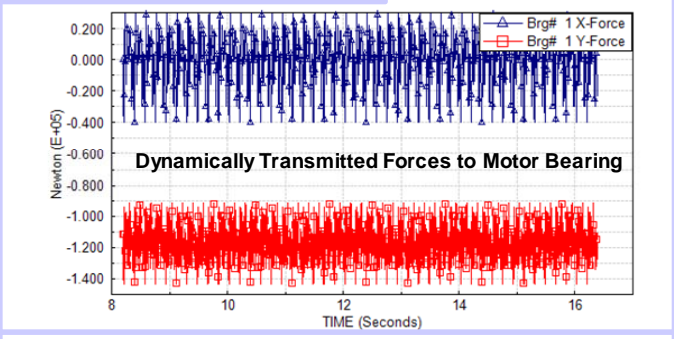
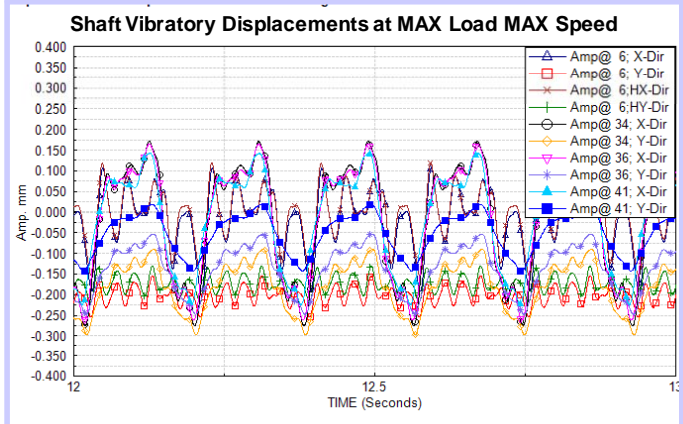

Purchasing Options

ARMD is constructed from various solution modules. It can be tailored to suit your needs and budget. You may purchase any combination of programs/modules or all if you wish. Licensing is available as a single seat or multi-seat network configuration. With your purchase, the package includes the software (CD or download), quick start manual, electronic user's manual, technology transfer and training session (optional), updates, maintenance, and support.

System Requirements:

Personal computer with Microsoft Windows 7, 8, 10 or higher (32 or 64 bit).

Remember, with **RBTS**, you get more than just the programs, you get the company with more than 50 years of experience in the areas of tribology and machinery dynamics.

For further information, please contact us.

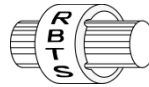

RBTS, Inc.

Rotor Bearing Technology & Software
1041 West Bridge Street
Phoenixville, PA 19460
USA

Telephone: **610-415-0412**
Facsimile: **610-415-0413**
Web: **www.rbts.com**
Email: **info@rbts.com**

ARMD[™] - The Worldwide Leading Software For Rotating Machinery Analysis

Advanced Rotating Machinery Dynamics

ARMD is a well established software package used worldwide to perform complete rotating machinery dynamic analysis. **ARMD** employs a user-friendly interface and window environment with pull-down menus and context-sensitive help. **ARMD** integrates the most advanced and complete rotor dynamics, torsional vibration, and bearing analysis programs under one environment in a seamless fashion to give you the power to model your rotating machinery with ease, efficiency, and above all accuracy. Some applications in which **ARMD** has been utilized include rotating machinery such as a miniature air turbine for a dental drill, a large turbine generator set for a power plant, a small compressor for an air conditioner, a pump for an artificial heart, a fuel pump for a jet engine, an electric motor and spindle for a miniature computer hard disk, a canned pump for petrochemical processing plant, synchronous motor driven drive-trains, and a gear box for an Uranium enrichment plant.

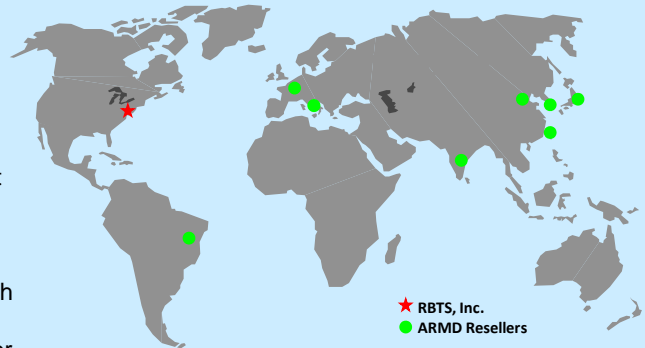

RBTS' software has gained international reputation for its:

- ◆ **Technical Capabilities**
- ◆ **User Friendliness**
- ◆ **Completeness**
- ◆ **Support & Service**



RBTS, Inc.

Rotor Bearing Technology & Software
1041 West Bridge Street
Phoenixville, PA 19460, USA